

X-15
NET WEIGHT: 4.8KG (with stand)
4.4KG (w/o stand)

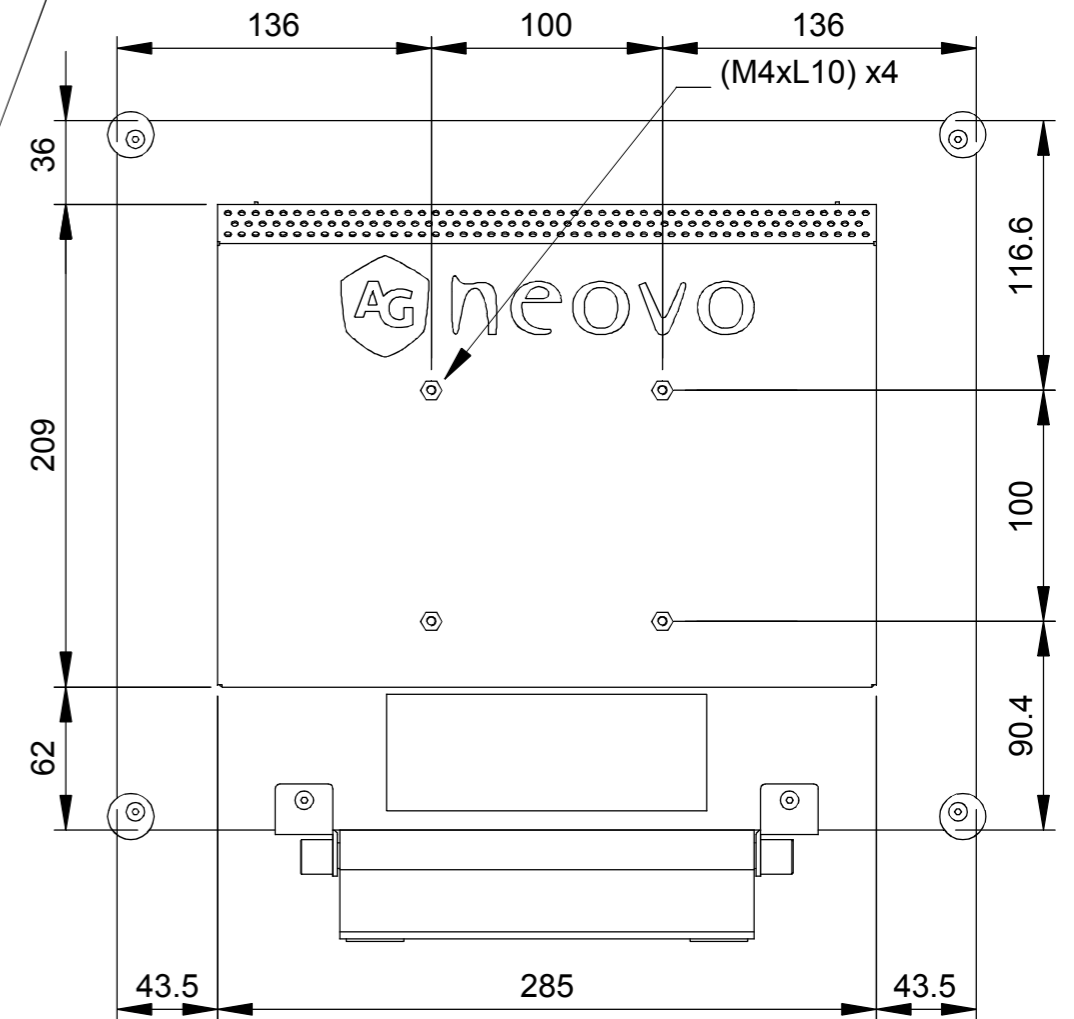
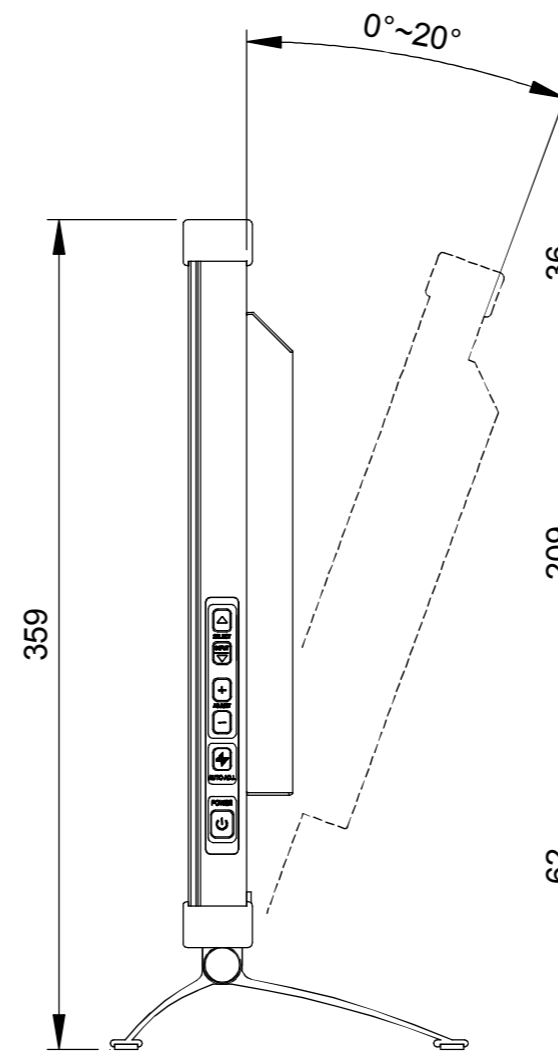
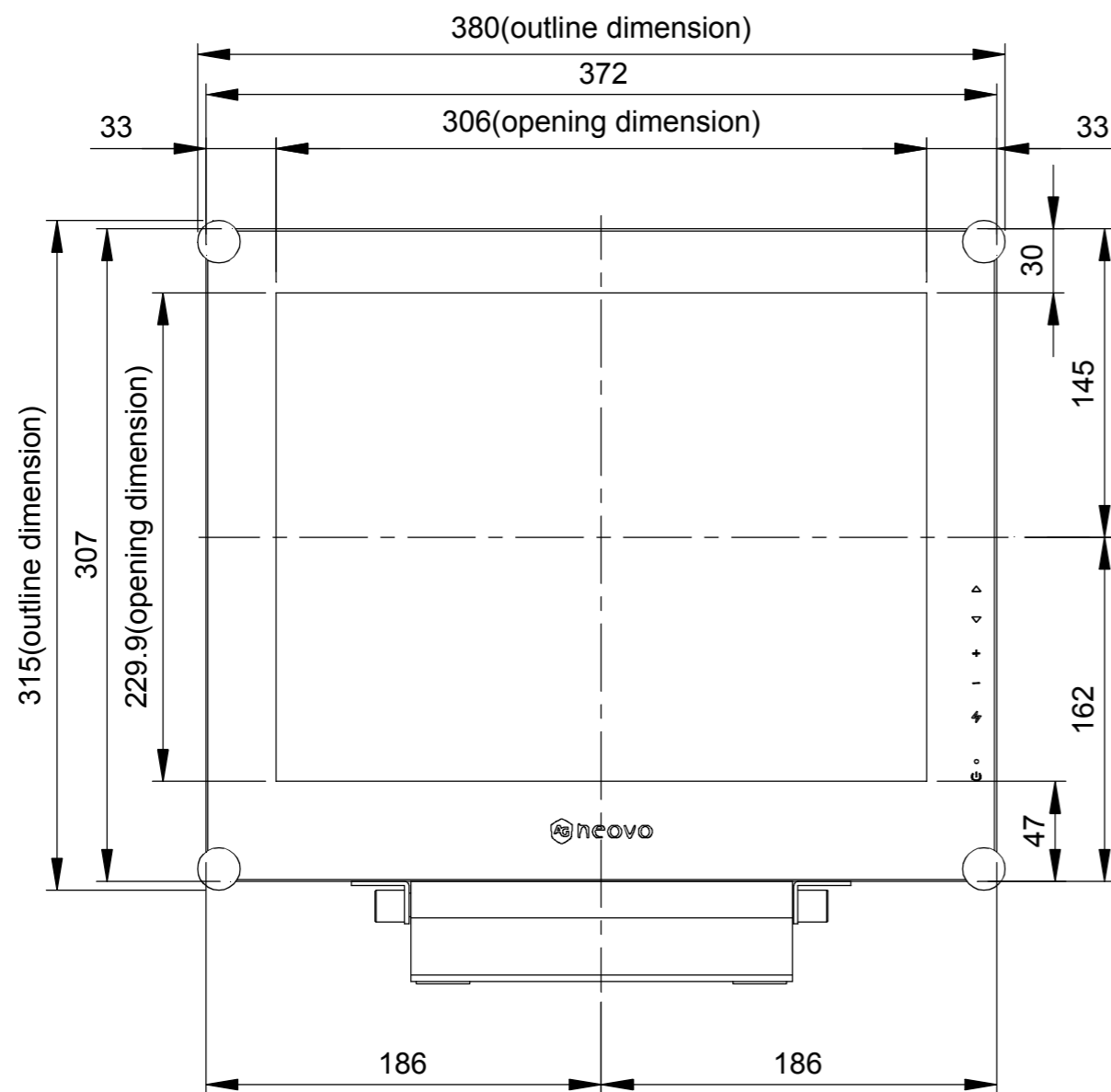

SPECIFICATIONS SUBJECT TO CHANGE WITHOUT NOTICE.

 www.agneovo.com	Model Name:
	X-15
<small>THIS DRAWING ON THIS PRINT AND INFORMATION BELONG WITH AG Neovo. ANY REPRODUCTION IN PART OR WHOLE WITHOUT WRITTEN PERMISSION OF AG Neovo IS PROHIBITED.</small>	<small>THIRD ANGLE PROJECTION</small>
SCALE 1:1	UNITS MM V.01