



FreeSpace® IZA 2120-LZ & IZA 2120-HZ Integrated Zone Amplifiers

FreeSpace® ZA 2120-LZA & ZA 2120-HZA Zone Amplifiers

Installation and Operation Guide
Guía de instalación y funcionamiento
Guide d'installation et d'utilisation
Installations- und Bedienungsanleitung
Manuale di installazione e funzionamento
Installatie- en bedieningshandleiding

Please read this owner's guide and save it for future reference.

This product is intended for installation by professional installers only! This document is intended to provide professional installers with basic installation and safety guidelines for this product in typical fixed-installation systems. Please read this document before attempting installation.



WARNINGS:

- All Bose products must be used in accordance with local, state, federal and industry regulations. It is the installer's responsibility to ensure installation of the product is performed in accordance with all applicable codes, including local building codes and regulations. Consult the local authority having jurisdiction before installing this product.



- To reduce the risk of fire or electrical shock, do not expose the product to rain or moisture.
- Do not expose this apparatus to dripping or splashing, and do not place objects filled with liquids such as vases, on or near the apparatus. Exposure to liquid may create a fire hazard.

- Do not place any naked flame sources, such as lighted candles, on or near the apparatus.

- This product is not intended for installation or use in indoor water facility areas (including, without limitation, indoor pools, indoor water parks, hot tub rooms, saunas, steam rooms and indoor skating rinks).



- Contains small parts which may be a choking hazard. Not suitable for children under age 3.

CAUTIONS:

- This product shall be connected to an AC mains socket outlet with a protective earthing (grounding) connection. Caution: Do not mount the chassis in locations where condensation may occur.

- Do not make unauthorized alterations to this product; doing so may compromise safety, regulatory compliance, system performance, and may void the warranty.

- Only use the mounting hardware recommended by the rack manufacturer.

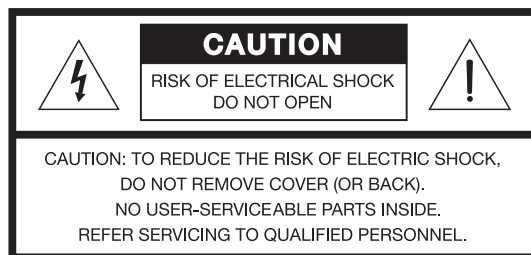

This symbol means there is uninsulated, dangerous voltage within the product enclosure that may constitute a risk of electrical shock.



This symbol means there are important operating and maintenance instructions in this guide.

NOTES:

- The product label is located on the bottom of the product.
- Where the mains plug or appliance coupler is used as the disconnect device, such disconnect device shall remain readily operable.
- This product is not designed or tested to be powered or charged by a power inverter.
- This product is not designed or tested for use in vehicles or boats.

For Japan:

Note: Provide an earth connection before the main plug is connected to the mains.

For Denmark, Finland, Norway, and Sweden:

English: The device must be connected to an outlet with a protective earth connection.

Danish: Apparatets stikprop skal tilsluttes en stikkontakt med jord, som giver forbindelse til stikproppens jord.

Finnish: Laitte on liitettävä suojamaadoituskoskettimilla varustettuun pistorasiaan.

Norwegian: Apparatet må tilkoples jordet stikkontakt.

Swedish: Apparaten skall anslutas till jordat uttag.

1. Read these instructions.
2. Keep these instructions.
3. Heed all warnings.
4. Follow all instructions.
5. Do not use this apparatus near water.
6. Clean only with a dry cloth.
7. Do not block any ventilation openings. Install in accordance with the manufacturer's instructions.
8. Do not install near any heat sources, such as radiators, heat registers, stoves, or other apparatus (including amplifiers) that produce heat.
9. Do not defeat the safety purpose of the polarized or grounding-type plug. A polarized plug has two blades with one wider than the other. A grounding-type plug has two blades and a third grounding prong. The wider blade or third prong is provided for your safety. If the provided plug does not fit in your outlet, consult an electrician for replacement of the obsolete outlet.
10. Protect the power cord from being walked on or pinched, particularly at plugs, convenience receptacles, and the point where they exit from the apparatus.
11. Only use attachments/accessories specified by the manufacturer.
12.  Use only with the cart, stand, tripod, bracket, or table specified by the manufacturer or sold with the apparatus. When a cart is used, use caution when moving the cart/apparatus combination to avoid injury from tip-over.
13. Unplug this apparatus during lightning storms or when unused for long periods of time to prevent damage to this product.
14. Refer all servicing to qualified service personnel. Servicing is required when the apparatus has been damaged in any way such as power-supply cord or plug is damaged; liquid has been spilled or objects have fallen into the apparatus; the apparatus has been exposed to rain or moisture, does not operate normally, or has been dropped.

 This product conforms to all applicable EU directive requirements. The complete Declaration of Conformity can be found at www.Bose.com/compliance.

This product meets all EN55103-2 immunity requirements for E2 electromagnetic environment.

Information About Products That Generate Electrical Noise (FCC Compliance Notice for US)

Note: This equipment has been tested and found to comply with the limits for a Class A digital device, pursuant to part 15 of the FCC Rules. These limits are designed to provide reasonable protection against harmful interference when the equipment is operated in a commercial environment. This equipment generates, uses, and can radiate radio frequency energy and, if not installed and used in accordance with the instruction manual, may cause harmful interference to radio communications. Operation of this equipment in a residential area is likely to cause harmful interference in which case the user will be required to correct the interference at one's own expense.

Changes or modifications not expressly approved by Bose Corporation could void the user's authority to operate this equipment.

This product complies with the Canadian ICES-003 Class A specifications.

CAN ICES-3(A)/NMB-3(A)

For China:



仅适用于海拔 2000m 以下地区安全使用
Only suitable for use at areas with altitude less than 2000 m.



仅适用于非热带气候条件下安全使用
Only suitable for use at non-tropic climate areas.

Lea esta guía del usuario y consérvela para consultarla en el futuro.

Este producto está diseñado para ser instalado únicamente por instaladores profesionales. Este documento está diseñado para proveer las pautas de seguridad e instalación básicas a los instaladores profesionales de este producto en sistemas de instalación fija comunes. Lea este documento antes de comenzar con su instalación.

ADVERTENCIA:



- Todos los productos Bose deben instalarse conforme a las leyes locales, estatales, federales y del sector. Es responsabilidad del instalador asegurarse de que la instalación del producto se realice conforme a las normas legales correspondientes, incluidas las normas de construcción locales. Consulte a la autoridad local competente antes de instalar este producto.



- Para reducir el riesgo de incendio o descarga eléctrica, no exponga este producto a la lluvia o la humedad.

- No exponga el aparato a goteos o salpicaduras y no coloque encima ni cerca del aparato objetos llenos de líquido; por ejemplo, floreros. La exposición a líquidos podría generar el riesgo de incendio.

- No coloque sobre el producto, o en su proximidad, fuentes de llamas sin protección; por ejemplo, velas encendidas.

- Este producto no está diseñado para ser instalado o utilizado en zonas de instalaciones de agua (incluidos, sin limitarse a, piscinas techadas, parques acuáticos techados, jacuzzis, saunas, salas de vapor y pistas de patinaje techadas).



Contiene piezas pequeñas que pueden suponer riesgo de asfixia. No adecuado para niños de menos de 3 años.

PRECAUCIÓN:

- Este producto deberá conectarse a una toma de corriente de CA con una conexión a tierra que sirva de protección.
- No realice alteraciones no autorizadas a este producto; esto podría comprometer la seguridad, el cumplimiento de las normas y el rendimiento del sistema, y podría anular la garantía.
- Utilice únicamente las herramientas de montaje que recomienda el fabricante del rack.



Este símbolo indica que dentro de la carcasa del producto hay voltaje peligroso y no aislado, que podría significar un riesgo de descarga eléctrica.



Este símbolo indica que en esta guía se incluyen instrucciones de mantenimiento y funcionamiento importantes.

NOTAS:

- La etiqueta del producto se encuentra en la parte inferior.
- Si se utiliza la clavija de conexión de red eléctrica o el acoplador del artefacto como el dispositivo de desconexión, dicho dispositivo de desconexión deberá permanecer listo para funcionar.
- Este producto no está diseñado ni probado para recibir alimentación o carga de un inversor.
- Este producto no está diseñado ni probado para utilizarse en embarcaciones o vehículos.

1. Lea estas instrucciones.
2. Guarde estas instrucciones.
3. Preste atención a las advertencias.
4. Siga todas las instrucciones.
5. No use este aparato cerca del agua.
6. Límpielo solamente con un paño seco.
7. No obstruya ninguna abertura de ventilación. Realice la instalación conforme a las instrucciones del fabricante.
8. No lo instale cerca de ninguna fuente de calor, como radiadores, rejillas de calefacción, estufas u otros aparatos (incluidos los amplificadores) que produzcan calor.
9. No anule el propósito de seguridad del enchufe con conexión a tierra o polarizado. Un enchufe polarizado tiene dos hojas, una más ancha que la otra. Un enchufe con conexión a tierra tiene dos clavijas planas y un tercer conector a tierra. La clavija plana más ancha o el tercer conector son para su seguridad. Si el enchufe suministrado no encaja en la toma de corriente, consulte con un electricista para cambiar la toma de corriente obsoleta.
10. Proteja el cable de alimentación para que nadie lo pise o lo perforo, especialmente en enchufes, receptáculos de tomas múltiples y en el punto donde salen del dispositivo.
11. Use solamente los accesorios especificados por el fabricante.
12.  Use solamente con el carro, el soporte de piso, el trípode, el soporte o la mesa especificado por el fabricante, o vendido con el dispositivo. Cuando se usa un carro, tenga precaución al moverlo con el dispositivo para evitar lesiones por tropiezos.
13. Desenchufe este aparato durante tormentas eléctricas o cuando no lo utilice durante períodos prolongados.
14. Derive todas las tareas de mantenimiento a personal calificado. Se requieren tareas de mantenimiento si el aparato se daña de alguna manera; por ejemplo, si se daña el enchufe o el cable de alimentación, si se derrama líquido o si caen objetos dentro del aparato, si el aparato se expone a la lluvia o la humedad, si no funciona normalmente; o bien, si se cae.

 Este producto cumple los requisitos de todas las Directivas de la UE aplicables legalmente. Encontrará la declaración de conformidad completa en www.Bose.com/compliance.

Este producto cumple con todos los requisitos de inmunidad de EN55103-2 para un entorno electromagnético E2.

Información sobre productos que generan ruido eléctrico (Nota de homologación FCC para EE UU)

Nota: Este equipo se ha probado y ha demostrado que cumple con los límites para dispositivos digitales de clase B, de acuerdo con el apartado 15 de las normas de la FCC. Estos límites están diseñados para ofrecer una protección razonable contra las interferencias perjudiciales cuando el aparato se utiliza en un entorno comercial. Este equipo genera, utiliza y puede irradiar energía de radiofrecuencia y, si no se instala y se utiliza de acuerdo con el manual de instrucciones, podría ocasionar interferencias perjudiciales para las comunicaciones por radio. La utilización de este equipo en una zona residencial podría causar interferencias dañinas. En ese caso, la corrección de la interferencia correrá a cargo del usuario.

Los cambios o las modificaciones no aprobadas expresamente por Bose Corporation podrían invalidar la autoridad del usuario para operar el equipo.

Este producto cumple las especificaciones canadienses para dispositivos de clase A ICES-003.
CAN ICES-3(A)/NMB-3(A)

Consultez attentivement cette notice d'utilisation et conservez-la pour toute référence future.

L'installation de ce produit doit être effectuée par un technicien professionnel ! Ce document à l'intention des installateurs professionnels contient les directives de pose et de sécurité relatives à ce produit en installation fixe. Lisez attentivement ce document avant l'installation.

AVERTISSEMENTS:



- Tous les produits Bose doivent être installés dans le respect des réglementations locales et nationales. L'installateur est responsable du respect de tous les codes et règlements locaux et nationaux en vigueur applicables à l'installation du produit. Consultez les autorités locales compétentes avant d'installer ce produit.



- Pour limiter les risques d'incendie ou d'électrocution, n'exposez pas l'appareil à la pluie ou à l'humidité.
- Protégez l'appareil de tout risque de ruissellement ou d'éclaboussure. Ne placez pas d'objets contenant des liquides, tels que des vases, sur l'appareil. L'exposition aux liquides peut induire un risque d'incendie.



- Ne placez jamais d'objets enflammés, tels que des bougies allumées, sur l'appareil.
- Ce produit n'est pas destiné à être monté ou utilisé dans des installations humides en intérieur (par exemple piscine intérieure, parc aquatique intérieur, baignoire à remous, sauna, hammam, patinoire intérieure, etc.).

Certaines pièces présentent un risque de suffocation. Ne pas laisser à la portée des enfants de moins de 3 ans.

ATTENTION:

- Cet appareil doit être raccordé à une prise secteur dotée d'une protection par mise à la terre.
- Toute modification non autorisée peut compromettre votre sécurité, le respect des réglementations et le bon fonctionnement de l'appareil, et en invalidera la garantie.
- Utilisez exclusivement le matériel de montage en rack recommandé par le fabricant.

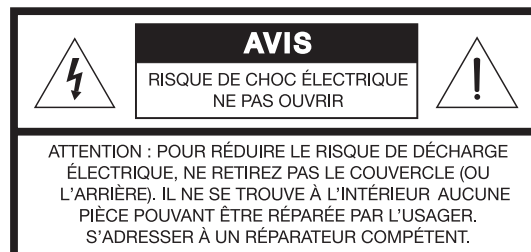

Ce symbole indique la présence d'une tension électrique dangereuse non isolée à l'intérieur de l'appareil, susceptible d'induire un risque de choc électrique.



Ce symbole signale la présence d'instructions importantes relatives au fonctionnement et à l'entretien de l'appareil dans ce guide.

REMARQUE:

- L'étiquette d'identification du produit est située au-dessous de l'appareil.
- Lorsque la fiche d'alimentation ou la prise multiple est utilisée comme dispositif de débranchement de l'appareil, elle doit rester facilement accessible.
- Ce produit n'a pas été conçu ou testé pour être alimenté ou chargé au moyen d'un onduleur.
- Ce produit n'a pas été conçu ou testé pour être utilisé dans des véhicules ou des bateaux.

1. Veuillez lire ces instructions.
2. Veuillez conserver ces instructions.
3. Respectez tous les avertissements.
4. Suivez toutes les instructions.
5. N'utilisez pas cet appareil à proximité d'eau ou d'une source d'humidité.
6. Utilisez uniquement un chiffon sec pour le nettoyage.
7. Ne bloquez jamais les orifices d'aération. Suivez les instructions du fabricant pour l'installation.
8. N'installez pas cet appareil à proximité d'une quelconque source de chaleur, telle qu'un radiateur, une arrivée d'air chaud, un four ou tout autre appareil (notamment des amplificateurs) produisant de la chaleur.
9. Veillez à profiter de la sécurité offerte par les fiches de type terre ou polarisées. Les fiches polarisées sont équipées de deux bornes de largeurs différentes. Les fiches de type terre sont équipées de deux bornes et d'un orifice pour la mise à la terre. Ces deux types de dispositifs ont pour but d'assurer votre sécurité. Si la prise fournie ne s'adapte pas à votre prise de courant, consultez un électricien pour qu'il remplace cette prise obsolète.
10. Protégez le cordon d'alimentation contre les risques de piétinement ou de pincement, notamment au niveau des fiches, des prises de courant et des branchements à l'appareil.
11. Utilisez uniquement les accessoires spécifiés par le fabricant.
12.  Utilisez uniquement le chariot, le support, le trépied, l'équerre ou la table spécifié(e) par le fabricant ou vendu(e) avec l'appareil. Si vous utilisez un chariot, faites attention à ne pas faire basculer l'ensemble chariot/appareil.
13. Débranchez cet appareil pendant les orages ou au cours des longues périodes de non utilisation.
14. Confiez toute réparation à du personnel qualifié. Une réparation est nécessaire lorsque l'appareil a été endommagé de quelque façon que ce soit (endommagement du cordon d'alimentation ou de la fiche électrique, renversement d'un liquide ou de tout objet sur l'appareil, exposition de l'appareil à la pluie ou à l'humidité, mauvais fonctionnement, chute de l'appareil, etc.).

CE Ce produit est conforme à toutes les directives de la Communauté Européenne qui s'y appliquent. L'attestation complète de conformité est disponible à l'adresse www.Bose.com/compliance.

Ce produit répond aux critères d'immunité de la norme EN55103-2 pour les environnements électromagnétiques classés E2.

Informations sur les produits générateurs de bruit électrique (Notice de conformité FCC pour les USA)

Remarque : ce matériel a fait l'objet de tests prouvant sa conformité aux limites imposées aux appareils numériques de classe A, conformément à la partie 15 des réglementations de la FCC. Ces limites sont conçues pour offrir une protection raisonnable contre les interférences nuisibles lorsque l'appareil est utilisé en environnement commercial. Cet appareil génère, utilise et est susceptible d'émettre de l'énergie à certaines fréquences radio. À ce titre, s'il n'est pas installé ou utilisé conformément aux instructions, il est susceptible de perturber les communications radio. L'utilisation de cet équipement dans une zone résidentielle risque de provoquer des interférences nuisibles, auquel cas l'utilisateur devra remédier au problème à ses propres frais.

Toute modification non autorisée expressément par Bose Corporation est susceptible d'annuler le droit de l'utilisateur à utiliser cet appareil.

Ce produit est conforme aux spécifications de la réglementation ICES-003 pour la classe A du Canada.
CAN ICES-3(A)/NMB-3(A)

Bitte lesen Sie diese Bedienungsanleitung durch und bewahren Sie sie zum späteren Nachschlagen auf.

Dieses Produkt darf nur von fachkundigen Monteuren installiert werden! Dieses Dokument soll fachkundigen Monteuren grundlegende Installations- und Sicherheitsrichtlinien für dieses Produkt in typischen Festinstallationsystemen bieten. Bitte lesen Sie dieses Dokument vor der Installation durch.

WARNUNG:



- Alle Produkte von Bose müssen gemäß den örtlichen und staatlichen Vorschriften sowie gemäß allen Branchenbestimmungen verwendet werden. Der Monteur ist dafür verantwortlich, sicherzustellen, dass die Installation des Produkts gemäß allen geltenden Vorschriften durchgeführt wird, einschließlich örtlicher Bauvorschriften und Bestimmungen. Wenden Sie sich vor der Installation dieses Produkts an die zuständige Abnahmebehörde.



- Um Brände und Stromschläge zu vermeiden, darf dieses Produkt weder Regen noch Feuchtigkeit ausgesetzt werden.
- Schützen Sie das Gerät vor tropfenden oder spritzenden Flüssigkeiten, und stellen Sie keine mit Flüssigkeiten gefüllten Gefäße (z. B. Vasen) auf das Gerät oder in die Nähe des Geräts. Durch den Kontakt mit Flüssigkeiten entsteht ggf. Brandgefahr.



- Stellen Sie keine brennenden Kerzen oder ähnliches auf das Gerät oder in die Nähe des Geräts.
- Dieses Produkt ist nicht für die Installation oder Verwendung in Innenbereichen mit Wassereinrichtungen (zum Beispiel Schwimmbädern, Wasserparks, Räume mit Whirlpools, Saunas, Dampfbäder und Eislaufbahnen) gedacht.

Enthält kleine Teile, die verschluckt werden können und eine Erstickungsgefahr darstellen. Nicht geeignet für Kinder unter drei Jahren.

ACHTUNG:

- Dieses Produkt muss an eine 230-V-Wechselstrom-Steckdose mit Erdungsschutz angeschlossen werden.
- Keine nicht autorisierten Veränderungen am Produkt vornehmen. Diese können die Sicherheit, die Einhaltung von Richtlinien und die Systemleistung beeinträchtigen. In diesem Fall kann die Garantie ungültig werden.
- Verwenden Sie nur die vom Rack-Hersteller empfohlenen Montagehilfsmittel.

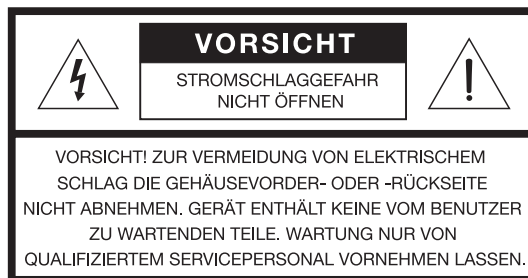

Dieser Warnhinweis warnt vor nicht isolierten gefährlichen Spannungsquellen im Inneren des Produktes, die ein Stromschlagrisiko darstellen können.



Dieser Warnhinweis weist auf wichtige Bedien- und Wartungsinformationen in dieser Anleitung hin.

HINWELS:

- Das Etikett mit der Produktbezeichnung befindet sich auf der Unterseite des Geräts.
- Falls Sie den Netzstecker oder eine Mehrfachsteckdose verwenden, um das Gerät von der Stromversorgung zu trennen, sollten Sie sicherstellen, dass Sie jederzeit auf den Stecker zugreifen können.
- Das Produkt wurde nicht für den Betrieb oder das Aufladen mit einem Wechselrichter entwickelt oder getestet.
- Das Produkt wurde nicht für den Betrieb in Fahrzeugen oder Booten entwickelt oder getestet.

1. Lesen Sie die folgenden Anweisungen.
2. Bewahren Sie die Anweisungen auf.
3. Beachten Sie alle Warn- und Sicherheitshinweise.
4. Befolgen Sie alle Anweisungen.
5. Verwenden Sie dieses Gerät nicht in der Nähe von Wasser.
6. Reinigen Sie das Gerät nur mit einem sauberen, trockenen Tuch.
7. Achten Sie darauf, dass die Lüftungsöffnungen nicht blockiert sind. Stellen Sie das Gerät nur in Übereinstimmung mit den Herstelleranweisungen auf.
8. Stellen Sie das Gerät nicht in der Nähe von Wärmequellen auf, wie Heizkörpern, Wärmespeichern, Öfen oder anderen Geräten (auch Verstärkern), die Wärme erzeugen.
9. Achten Sie darauf, dass die Schutzfunktion des Schutzkontaktsteckers nicht beeinträchtigt wird. Ein gepolter Stecker hat zwei Stromkontakte, von denen einer breiter als der andere ist. Ein Schutzkontaktstecker hat zwei Stromkontakte und einen dritten Erdungskontakt. Der breite bzw. dritte Kontakt dient Ihrer Sicherheit. Falls der mitgelieferte Stecker nicht in Ihre Steckdose passt, wenden Sie sich an einen qualifizierten Elektriker, um die Steckdose auszutauschen.
10. Verlegen Sie das Netzkabel so, dass es keine Stolpergefahr darstellt und nicht beschädigt werden kann – insbesondere im Bereich von Steckern und Steckdosen und dort, wo das Netzkabel aus dem Gerät herausgeführt wird.
11. Verwenden Sie nur Zubehör-/Anbauteile, die vom Hersteller zugelassen sind.
12.  Verwenden Sie für das Gerät nur Rollwagen, Ständer, Dreibeine, Halterungen oder Tische, die vom Hersteller zugelassen sind oder zusammen mit dem Gerät verkauft werden. Falls Sie einen Rollwagen verwenden, dürfen Sie die Einheit Gerät/Rollwagen nur mit Vorsicht bewegen, damit Verletzungen beim möglichen Umkippen ausgeschlossen sind.
13. Ziehen Sie das Netzkabel bei Gewitter oder bei längerer Nichtbenutzung des Gerätes aus der Steckdose.
14. Alle Reparatur- und Wartungsarbeiten nur von qualifiziertem Kundendienstpersonal durchführen lassen. Wartungsarbeiten sind in folgenden Fällen nötig: Bei jeglichen Beschädigungen wie z. B. des Netzkabels oder Netzsteckers, wenn Flüssigkeiten oder Gegenstände in das Gehäuse gelangt sind, das Gerät Regen oder Feuchtigkeit ausgesetzt wurde, fallen gelassen wurde oder nicht ordnungsgemäß funktioniert.

 Dieses Produkt erfüllt alle vorgeschriebenen EU-Richtlinien. Die vollständige Konformitätserklärung ist einsehbar unter www.Bose.com/compliance.

Dieses Produkt erfüllt alle Anforderungen nach EN55103-2 für elektromagnetische Verträglichkeit.

Informationen über Produkte, die elektrisches Rauschen verursachen (Hinweis zur FCC-Einhaltung für die USA)

Hinweis: Dieses Gerät wurde geprüft. Es stimmt mit den Regelungen für Geräte der Klasse A gemäß Teil 15 der FCC-Vorschriften überein. Diese Grenzwerte sollen einen angemessenen Schutz gegen elektromagnetische Störungen beim Betrieb in gewerblicher Umgebung gewährleisten. Dieses Gerät erzeugt und verwendet Hochfrequenzstrahlung und kann sie auch aussenden. Daher verursacht das Gerät, wenn die Installation und Benutzung nicht in Übereinstimmung mit dieser Bedienungsanleitung erfolgt, möglicherweise Störungen des Funkverkehrs. Beim Betrieb dieses Geräts in Wohngebieten können erhebliche Störungen des Funkverkehrs verursacht werden. Eventuell daraus entstehende Kosten trägt allein der Benutzer des Geräts.

Veränderungen am Gerät, die nicht durch die Bose Corporation autorisiert wurden, können zur Folge haben, dass die Betriebserlaubnis für das Gerät erlischt.

Dieses Produkt erfüllt die kanadische Richtlinie ICES-003, Klasse A.
CAN ICES-3(A)/NMB-3(A)

Leggere questo manuale d'uso e conservarlo come riferimento per il futuro.

Questo prodotto deve essere installato esclusivamente da installatori professionisti. Il presente documento ha lo scopo di fornire agli installatori professionisti le istruzioni di base per l'installazione e la sicurezza de prodotto negli impianti convenzionali a installazione fissa. Leggere attentamente il documento prima di procedere all'installazione.

AVVERTENZA:



- Tutti i prodotti Bose devono essere installati in conformità con gli standard locali, statali, federali e di settore. È responsabilità dell'installatore assicurare che l'installazione del prodotto sia eseguita in conformità con tutte le normative vigenti, compresi i regolamenti edilizi locali. Prima di installare il prodotto, chiedere informazioni all'autorità locale preposta.
- Per ridurre il rischio di incendio o scosse elettriche, il prodotto non deve essere esposto a pioggia o umidità.



- Non esporre l'apparecchio a gocce o schizzi, e non porre oggetti contenenti liquidi quali vasi sopra o in prossimità dell'apparecchio. L'esposizione ai liquidi può provocare il rischio di incendi.

- Non collocare sorgenti di fiamme libere (ad esempio, candele accese) sull'apparecchio o in prossimità di esso.

- Il prodotto non deve essere installato o utilizzato in aree di servizio o intrattenimento vicine all'acqua (ad esempio, piscine coperte, parchi acquatici al chiuso, sale con vasche riscaldate, saune, bagni turchi e piste di pattinaggio al chiuso).



Contiene pezzi di piccole dimensioni che possono rappresentare un pericolo di soffocamento. Non adatto per bambini di età inferiore ai 3 anni.

ATTENZIONE:

- Questo prodotto deve essere collegato a una presa di corrente alternata dotata di un impianto protettivo di messa a terra.
- Eventuali modifiche non autorizzate possono compromettere la sicurezza, la conformità alle normative e le prestazioni del sistema, e quindi invalidare la garanzia.
- Utilizzare esclusivamente l'hardware di montaggio raccomandato dal produttore dell'unità rack.



Questo simbolo segnala la presenza di tensione non isolata e pericolosa all'interno dell'involucro del prodotto, con il rischio di scossa elettrica.



Questo simbolo segnala le istruzioni importanti dal punto di vista del funzionamento e della manutenzione all'interno della guida.

NOTAS:

- L'etichetta identificativa è situata sul fondo del prodotto.
- La spina dell'alimentazione o dell'accoppiatore deve essere raggiungibile facilmente e rapidamente se è utilizzata come dispositivo di spegnimento.
- Il prodotto non è progettato o testato per l'alimentazione o la ricarica mediante convertitore di corrente.
- Il prodotto non è progettato o testato per l'utilizzo su veicoli o natanti.

1. Leggere queste istruzioni.
2. Conservare queste istruzioni.
3. Prestare attenzione a tutte le avvertenze.
4. Seguire tutte le istruzioni.
5. Non utilizzare l'apparecchio in prossimità di acqua.
6. Utilizzare solo un panno asciutto per la pulizia.
7. Non ostruire le aperture di ventilazione. Installare il prodotto in conformità con le istruzioni fornite dal produttore.
8. Non installare i diffusori in prossimità di fonti di calore, quali termosifoni, radiatori, stufe o altri apparecchi (compresi gli amplificatori) che generano calore.
9. Non escludere l'obiettivo di sicurezza della spina polarizzata o con messa a terra. Una spina polarizzata è dotata di due poli, uno più largo dell'altro. Una spina con messa a terra è dotata di due poli e di un terzo terminale di massa. Il polo largo o il terzo terminale sono presenti per sicurezza. Se la spina in dotazione non è adatta alla presa, rivolgersi a un elettricista per la sostituzione della presa obsoleta.
10. Fare in modo che il cavo di alimentazione non venga calpestato o schiacciato, soprattutto in corrispondenza di spine, prese e nel punto di uscita dall'apparecchio.
11. Utilizzare solo sistemi di aggancio/accessori specificati dal produttore.
12.  Utilizzare solo carrelli, supporti, treppiedi, staffe o tavoli specificati dal produttore o venduti insieme all'apparato. Quando si utilizza un carrello, prestare attenzione durante lo spostamento dell'insieme carrello/apparecchio per evitare di rovesciarlo causando danni.
13. Scollegare l'apparecchio durante i temporali o quando rimane inutilizzato a lungo.
14. Affidarsi a personale qualificato per tutti gli interventi di assistenza. Gli interventi di assistenza si rendono necessari quando l'apparato ha subito danni di qualsiasi tipo, ad esempio se il cavo di alimentazione o la spina sono danneggiati, se è stato versato del liquido o sono caduti oggetti sull'apparato, se l'apparato è stato esposto a pioggia o umidità, se non funziona normalmente o è caduto.

CE Questo prodotto è conforme a tutte le direttive EU prescritte dalla legge. La dichiarazione di conformità completa è disponibile all'indirizzo www.Bose.com/compliance.

Il prodotto è conforme a tutti i requisiti di immunità EN55103-2 per ambienti elettromagnetici di tipo E2.

Informazioni sui prodotti che generano interferenze elettriche (avviso di conformità FCC per gli Stati Uniti)

Nota: Questa apparecchiatura è stata sottoposta a collaudo ed è risultata conforme ai limiti relativi ai dispositivi digitali di Classe A previsti dalla parte 15 delle norme FCC. Tali limiti sono stati fissati allo scopo di assicurare un'adeguata protezione dalle interferenze dannose quando l'apparecchiatura è utilizzata in un'installazione commerciale. Questa apparecchiatura genera, utilizza e può irradiare energia a radiofrequenza e, se non installata e utilizzata in conformità con il manuale di istruzioni, può interferire negativamente con le comunicazioni radiofoniche. L'utilizzo di questa apparecchiatura in un'area residenziale può provocare interferenze dannose, nel qual caso l'utente dovrà adottare misure correttive a proprie spese.

Eventuali modifiche o alterazioni non espressamente approvate da Bose Corporation possono rendere nulla l'autorizzazione dell'utente all'utilizzo dell'apparecchiatura stessa.

Questo prodotto è conforme alle specifiche canadesi ICES-003 per i prodotti di Classe A.
CAN ICES-3(A)/NMB-3(A)

Lees deze gebruikershandleiding zorgvuldig door en bewaar deze voor toekomstig gebruik.

Dit product is uitsluitend bestemd voor installatie door professionele installateurs! Dit document is bedoeld om professionele installateurs essentiële installatie- en veiligheidsrichtlijnen te bieden voor dit product in standaardssystemen voor vaste installatie. Lees dit document door voordat u begint met de installatie.

WAARSCHUWINGEN:

- Alle Bose-producten moeten worden geïnstalleerd volgens de plaatselijke en landelijke voorschriften en industriënormen. Het is de verantwoordelijkheid van de installateur om ervoor te zorgen dat de installatie van het product wordt uitgevoerd volgens alle van toepassing zijnde voorschriften, inclusief plaatselijke bouwvoorschriften. Neem contact op met de juiste plaatselijke overheidsinstanties voordat u dit product installeert.



- Stel het apparaat niet bloot aan regen of vocht, om het risico van brand of elektrische schokken te verlagen.
- Stel dit apparaat niet bloot aan druipende of spattende vloeistoffen en plaats geen met vloeistoffen gevulde voorwerpen, zoals vazen, op of bij het apparaat. Blootstelling aan vloeistoffen kan leiden tot brandgevaar.



- Plaats geen open vlam, zoals een brandende kaars, op of bij het product.
- Dit product is niet bedoeld voor installatie of gebruik in overdekte ruimten voor wateractiviteiten (waaronder overdekte zwembaden, overdekte waterparken, stoomruimten, sauna's, bubbelbadkamers en overdekte ijsbanen).

Bevat kleine onderdelen die een verstikkingsgevaar kunnen vormen. Niet geschikt voor kinderen jonger dan 3 jaar.

WAARSCHUWINGEN:

- Dit product moet worden aangesloten op een geaard AC-stopcontact.
- Er mogen geen wijzigingen aan het product worden aangebracht door onbevoegden. Dergelijke wijzigingen kunnen de veiligheid, de naleving van voorschriften en de werking van het systeem in gevaar brengen en kunnen ertoe leiden dat de garantie vervalt.
- Gebruik uitsluitend het door de fabrikant aanbevolen montagemateriaal.



Dit symbool duidt op gevaarlijke niet-geïsoleerde spanning in de behuizing van het product die tot elektrische schokken kan leiden.



Dit symbool geeft aan dat deze handleiding belangrijke gebruiks- en onderhoudsinstructies bevat.

OPMERKINGEN:

- Het productlabel bevindt zich aan de onderkant van het product.
- Wanneer de netstekker of aansluiting van een apparaat als stroomonderbreker wordt gebruikt, dient deze stroomonderbreker steeds goed bereikbaar te zijn.
- Dit product is niet ontworpen voor of getest op gebruik met een omvormer voor voeding of opladen.
- Dit product is niet ontworpen voor of getest op gebruik in voertuigen of vaartuigen.

1. Lees deze instructies door.
2. Bewaar deze instructies.
3. Neem alle waarschuwingen in acht.
4. Volg alle instructies.
5. Gebruik dit apparaat niet in de buurt van water.
6. Alleen met een droge doek reinigen.
7. Zorg dat u de ventilatieopeningen niet blokkeert. Installeer het apparaat volgens de instructies van de fabrikant.
8. Installeer het product niet in de buurt van warmtebronnen, zoals radiatoren, warmteroosters, kachels of andere apparaten (waaronder versterkers) die warmte produceren.
9. Schakel de functie van de gepolariseerde of geaarde stekker niet uit. Een gepolariseerde stekker heeft twee poten, waarvan de ene breder is dan de andere. Een geaarde stekker heeft twee poten en een pin voor de aarding. De brede poot of de derde poot is bedoeld voor uw veiligheid. Als de bijgeleverde stekker niet in het stopcontact past, neem dan contact op met een elektricien om het verouderde stopcontact te vervangen.
10. Zorg dat er niet op het netsnoer wordt gestaan of gelopen en dat het niet wordt afgeknelld, met name bij de stekkers en stopcontacten en het punt waar deze uit het apparaat komen.
11. Gebruik uitsluitend aansluitstukken/accessoires die door de fabrikant worden gespecificeerd.
12.  Gebruik het product uitsluitend in combinatie met het verrijdbare plateau, het statief, de beugel of de tafel die door de fabrikant worden vermeld of samen met het apparaat worden verkocht. Als u een verrijdbaar plateau gebruikt, moet u het apparaat en het plateau voorzichtig verplaatsen zodat deze niet kunnen omvallen en letsel veroorzaken.
13. Haal de stekker van dit apparaat uit het stopcontact bij onweer of als het langere tijd niet wordt gebruikt.
14. Laat alle reparaties en onderhoud over aan bevoegde servicemedewerkers. Onderhoud is vereist als het apparaat is beschadigd. Dit is bijvoorbeeld het geval als het netsnoer of de stekker is beschadigd, als er vloeistof is gemorst of voorwerpen in het apparaat zijn gevallen, als het apparaat is blootgesteld aan regen of vocht, niet normaal werkt of is gevallen.

 Dit product voldoet aan alle vereisten van de EU-richtlijnen, zoals wettelijk vereist. De volledige conformiteitsverklaring kunt u vinden op www.Bose.com/compliance.

Dit product voldoet aan alle immuniteitseisen van EN55103-2 voor een E2 elektromagnetische omgeving.

Informatie over producten die elektrische ruis genereren (FCC Compliance Notice voor de VS)

Opmerking: Dit apparaat is getest waarbij is vastgesteld dat het voldoet aan de limieten voor een digitaal apparaat van klasse A, volgens deel 15 van de FCC-voorschriften. Deze limieten zijn bedoeld om redelijke bescherming te bieden tegen schadelijke storing bij installatie in een handelsomgeving. Dit apparaat genereert en gebruikt radiofrequente energie en kan deze uitstralen en het kan, als het niet geïnstalleerd en gebruikt wordt volgens de instructies, schadelijke storing veroorzaken aan radiocommunicatie. Gebruik van dit apparaat in een woonwijk kan schadelijke storing veroorzaken. In dit geval is de gebruiker verplicht op eigen kosten de storing te verhelpen.

Veranderingen of aanpassingen die niet uitdrukkelijk zijn goedgekeurd door Bose Corporation kunnen leiden tot het vervallen van de bevoegdheid van de gebruiker om dit apparaat te gebruiken.

Dit product voldoet aan de specificaties van de Canadese ICES-003 klasse A.
CAN ICES-3(A)/NMB-3(A)

Introduction

Product Overview 16

 FreeSpace® IZA 2120-LZ / IZA 2120-HZ Integrated Zone Amplifier 16

 FreeSpace® ZA 2120-LZA / ZA 2120-HZA Zone Amplifier 16

Included Accessories 16

Front and Rear Panels

FreeSpace® IZA 2120-LZ 17

 IZA 2120-LZ Front Panel 17

 IZA 2120-LZ Rear Panel 18

FreeSpace® IZA 2120-HZ 19

 IZA 2120-HZ Front Panel 19

 IZA 2120-HZ Rear Panel 20

FreeSpace® ZA 2120-LZA/HZA 21

 ZA 2120-LZA/HZA Front Panel 21

 ZA 2120-LZA/HZA Rear Panel 22

Installation and Operation

Installation 23

 Importance of Proper Ventilation 23

 Rack Mounting 23

 Removing Rack-Mount Ears 23

 Placing on a Flat Surface 24

 Installing the Feet on the Amplifier 24

 Stacking Units 24

Remote Volume Control 25

 Connecting an Amplifier to a ControlSpace® Engineered Sound Processor 25

 Page Input Connections 25

 Remote Control Connections 26

 Remote Connections to Zone Amplifiers 28

Connecting a ControlCenter Zone Controller 30

 Connecting the CC-1 to a FreeSpace® Amplifier 30

 Connecting the CC-2 to a FreeSpace® Amplifier 32

Loudspeaker Usage 33

Expanding an IZA System with a ZA Amplifier 34

 Expansion Overview 34

 Connecting an IZA 2120-LZ/HZ Amplifier to a ZA 2120-LZA/HZA Amplifier 34

 Line Input Connections 34

 Connecting an IZA 2120-LZ/HZ Amplifier to Multiple Zone Amplifiers 35

Technical Information

AC Current Draw and Thermal Dissipation Information 36

Limited Warranty 37

Technical Specifications 38

 IZA 2120-LZ Specifications 38

 IZA 2120-HZ Specifications 39

 ZA 2120-LZA Specifications 40

 ZA 2120-HZA Specifications 41

Troubleshooting 42

Block Diagrams

IZA 2120-LZ Integrated Zone Amplifier 43
IZA 2120-HZ Integrated Zone Amplifier 44
ZA 2120-LZA Zone Amplifier 45
ZA 2120-HZA Zone Amplifier 46

Additional Resources

Contact Information 47
 Importer Information 47

Product Overview

This guide provides installation and operating information for FreeSpace® IZA 2120-LZ / IZA 2120-HZ integrated zone amplifiers and ZA 2120-LZA / ZA 2120-HZA zone amplifiers.

FreeSpace® IZA 2120-LZ / IZA 2120-HZ Integrated Zone Amplifier

The FreeSpace® IZA 2120-LZ / IZA 2120-HZ integrated zone amplifier provides signal processing, routing, paging, zoning and amplification for a wide range of commercial applications such as retail stores, restaurants and bars, hospitality venues, conference rooms, schools and auxiliary zones.

The integrated zone amplifier offers a variety of input connections (mic/line/page), input gain and output level adjustments, and operational modes. Built-in Bose® FreeSpace and DesignMax loudspeaker EQ presets can be selected for loudspeaker optimization.

FreeSpace® ZA 2120-LZA / ZA 2120-HZA Zone Amplifier

The FreeSpace ZA 2120-LZA / ZA 2120-HZA zone amplifier makes system expansion easy. Simply connect the auxiliary output of an IZA integrated zone amplifier to the input of a ZA zone amplifier. The two amplifiers will function together as one system sharing the same music, paging sources, master volume control and optional loudspeaker equalization.

ZA zone amplifiers are designed to expand sound systems that utilize front end signal processing from products such as the Bose FreeSpace® IZA 2120-LZ, IZA 2120-HZ, IZA 250-LZ and IZA 190-HZ integrated zone amplifiers and Bose ControlSpace® engineered sound processors. With the inclusion of AmpLink, up to the first 8 digital audio channels can be sent to the amplifier from a Bose DSP via a shielded CAT 5 cable. The FreeSpace ZA 2120-LZA / ZA 2120-HZA zone amplifiers can also be used as stand-alone amplifiers from any balanced or unbalanced line-level source.

Included Accessories

Each FreeSpace® amplifier carton contains one amplifier plus the items indicated in the following table:

| | IZA 2120-LZ | IZA 2120-HZ | ZA 2120-LZA | ZA 2120-HZA |
|------------------------|------------------|------------------|------------------|------------------|
| Feet with locking pins | 4 | 4 | 4 | 4 |
| 5-pin Euroblock | 2 | 2 | 1 | 1 |
| 4-pin Euroblock | 1 black, 1 green | 2 black, 1 green | | |
| 2-pin Euroblock | 1 black, 2 green | 1 black, 2 green | 1 black, 2 green | 1 black, 2 green |
| RCA cable | | | 1 | 1 |
| AC power cord* | 1 | 1 | 1 | 1 |
| Owners Guide | 1 | 1 | 1 | 1 |

*The appropriate power cord for your region is included.

Figure 1. FreeSpace amplifier carton contents

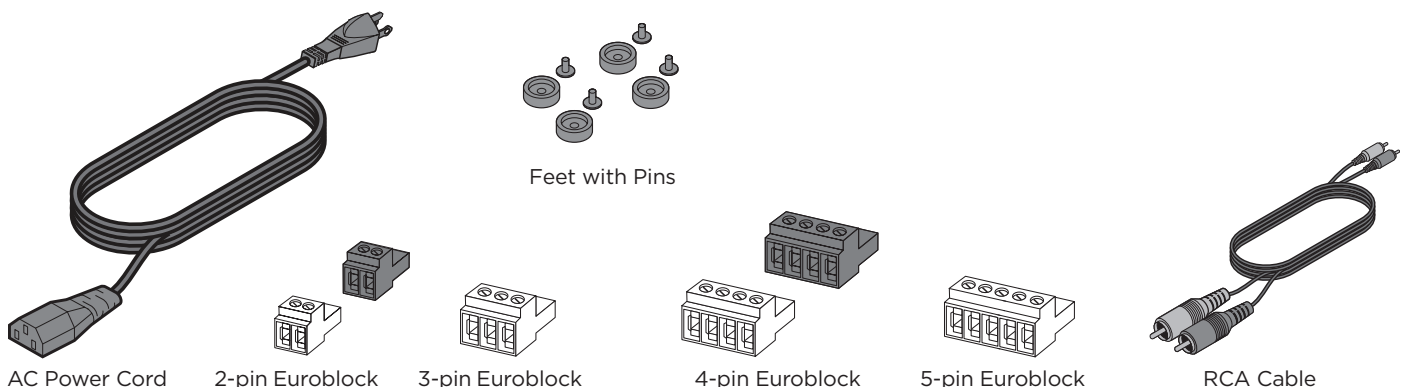

FreeSpace® IZA 2120-LZ

The four-input IZA 2120-LZ mixer amplifier is optimized for low-impedance stereo or mono applications. It supports loudspeaker EQs for the FreeSpace FS2C/SE/P, FS4CE/SE, and DesignMax DM2C-LP/S, DM3C/SE.

IZA 2120-LZ Front Panel

Figure 2. FreeSpace IZA 2120-LZ amplifier front panel

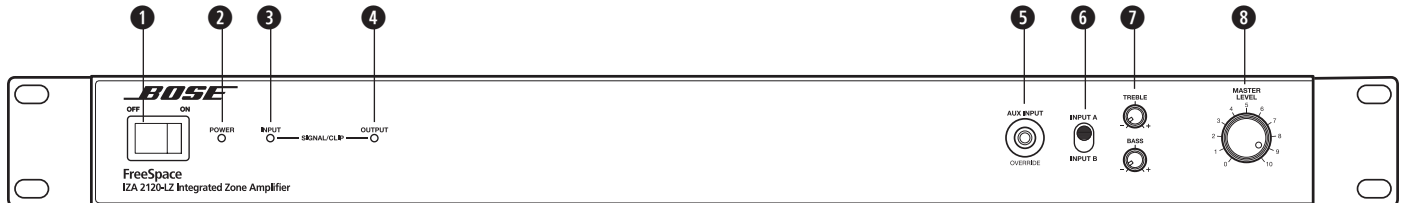

- ❶ **POWER Switch** - ON/OFF AC power.
- ❷ **POWER LED** - Solid blue LED indicates the unit is ON. Blinking blue LED indicates the unit is in standby mode.
- ❸ **INPUT SIGNAL LED** - LED is green from -37 dBu to 11 dBu, LED goes red over 11 dBu. MASTER LEVEL set at 5.
- ❹ **OUTPUT LIMIT LED** - LED is green from -46 dBFS to -2 dBFS, LED goes red over -2 dBFS, approximately 80 W/channel. For each output, 120 watts is 0 dBFS.
- ❺ **AUX INPUT** - 1/8" (3.5 mm) stereo line-level input connector. A cable insertion mutes INPUT A and INPUT B for priority override. Pages can still be made from the PAGE INPUT. AUX INPUT does not have any gain adjustment, therefore, all gain adjustments must be done from the external source device.
- ❻ **INPUT A/B Switch** - Allows selection of rear line-input channels A or B.
- ❼ **TREBLE/BASS Controls** - Allows tonal adjustments of both outputs simultaneously. These are 1st order shelving filters that provide ± 6 dB adjustment at 7 kHz and above (TREBLE) and 100 Hz and below (BASS). They have a slope of approximately 6 dB/octave.
- ❽ **MASTER LEVEL Control** - Controls the overall system volume for both the loudspeakers and the AUX OUTPUT when the AUX OUTPUT DIP switch is set to VARIABLE. If the AUX OUTPUT DIP switch is set to FIXED, the AUX OUTPUT maintains maximum level.

Note: When using a REMOTE volume connection, the front panel MASTER LEVEL control becomes disabled. See "Remote Control Connections" on page 26 for more details.

IZA 2120-LZ Rear Panel

Figure 3. FreeSpace IZA 2120-LZ amplifier rear panel

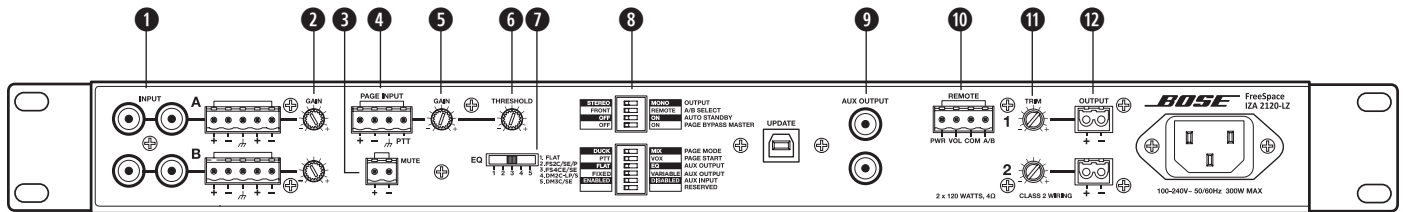

- ❶ **INPUT A/B** - Balanced and unbalanced line-level input connectors.
- ❷ **INPUT GAIN** - Allows for 0 dB to -30 dB of adjustment to each INPUT A/B.
- ❸ **MUTE** - Contact closure connection that upon trigger (short) will mute all outputs (including AUX OUTPUT).
- ❹ **PAGE INPUT** - Euroblock mic/line input that supports dynamic microphones with voice activation (VOX) or a trigger contact closure for use with push-to-talk (PTT) microphones.
- ❺ **PAGE INPUT GAIN** - Allows for 0 dB to +50 dB of gain control of PAGE INPUT signal.
- ❻ **PAGE INPUT THRESHOLD** - Adjusts the level at which the VOX PAGE INPUT signal causes other inputs to be lowered. A 10 dB adjustment range lifts the page trigger level away from the noise floor to prevent false triggers. At minimum setting, a -70 dBu signal will trigger a VOX page. At maximum setting, a -60 dBu signal will trigger a VOX page. When in PTT page mode this adjustment is not active.
- ❼ **EQ** - Provides loudspeaker equalization presets: Flat, FreeSpace FS2C/SE/P, FS4CE/SE, DesignMax DM2C-LP/S, DM3C/SE. Use the Flat setting for loudspeakers that are not Bose or that do not require EQ.
- ❽ **DIP Switches** - A bank of switches to set the amplifier configuration. All switches set to the left position is the standard configuration.
 - **OUTPUT** - Sets the outputs to either STEREO or MONO mode.
 - **A/B SELECT** - Determines if A/B inputs are selected by the front panel INPUT A/INPUT B switch (FRONT) or the rear panel remote control input (REMOTE).
 - **AUTO STANDBY** - If enabled (ON) the amplifier will go into standby mode after twenty minutes without an input signal. If in standby mode and an audio signal is detected, the amplifier will automatically wake and amplify audio within 0.7 seconds. The OFF position disables this feature.
 - **PAGE BYPASS MASTER** - Sets the paging volume to follow the front panel MASTER LEVEL setting (OFF) or to output maximum volume (ON). The PAGE INPUT GAIN adjustment is available in either mode. Use this feature if the output volume is too low to hear a page.
 - **PAGE MODE** - Sets the amplifier to mix paging (MIX) with the selected input source or to duck the input source (DUCK) when paging is activated.
 - **PAGE START** - Determines if paging is to be activated by a push-to-talk (PTT) stimulus or voice stimulus (VOX).
 - **AUX OUTPUT (FLAT/EQ)** - Determines if the auxiliary output will either have no EQ adjustment (FLAT) or an EQ adjustment determined by the EQ slide switch position (EQ).
 - **AUX OUTPUT (FIXED/VARIABLE)** - Sets the auxiliary output level to either follow the front panel MASTER LEVEL control setting (VARIABLE), or to the maximum output level (FIXED).
 - **AUX INPUT** - Enables (ENABLED) or disables (DISABLED) the auxiliary input. If enabled, inserting a cable into the auxiliary input will mute INPUT A and B.
- ❹ **AUX OUTPUT** - Variable or fixed, unbalanced line-level output signal for use with ZA zone amplifiers or for routing the signal to additional audio equipment.
- ❺ **REMOTE** - Input connector for either a ControlCenter CC-2 zone controller for volume control and A/B source selection or a ControlCenter CC-1 zone controller for volume control only.
- ❻ **OUTPUT 1/OUTPUT 2 TRIM** - Allows for up to 40 dB attenuation of the individual loudspeaker outputs relative to the master level.
- ❼ **OUTPUT** - Two inverted 2-pin Euroblock connectors for loudspeaker connections. Outputs are not bridgeable.

FreeSpace® IZA 2120-HZ

The six-input IZA 2120-HZ mixer-amplifier is optimized for dual-zone high-impedance applications. It has the ability to independently adjust the EQ, bass/treble level, and volume control (with A/B source selection via two remote controls) for each zone.

This mixer-amplifier supports loudspeaker EQs for the FreeSpace FS2C/SE/P, FS4CE/SE, and DesignMax DM2C-LP/S, DM8C-SUB/FS3B. Since each output supports an independent EQ, the amplifier has the ability to bi-amp by driving a loudspeaker with EQ on one channel and a sub with EQ on the second channel, or any required combination.

IZA 2120-HZ Front Panel

Figure 4. FreeSpace IZA 2120-HZ amplifier front panel

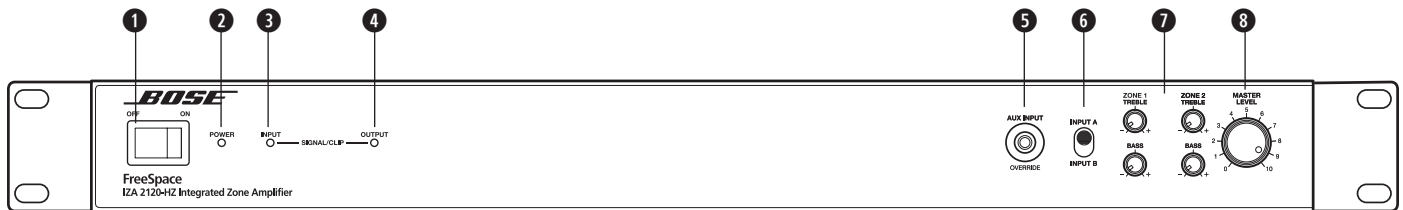

- ❶ **POWER Switch** - ON/OFF AC power.
- ❷ **POWER LED** - Solid blue LED indicates the unit is ON. Blinking blue LED indicates the unit is in standby mode.
- ❸ **INPUT SIGNAL LED** - LED is green from -37 dBu to 11 dBu, LED goes red over 11 dBu. MASTER LEVEL set at 5.
- ❹ **OUTPUT LIMIT LED** - LED is green from -46 dBFS to -2 dBFS, LED goes red over -2 dBFS, approximately 80 W/channel. For each output, 120 watts is 0 dBFS.
- ❺ **AUX INPUT** - $1/8"$ (3.5 mm) stereo line-level input connector. A cable insertion mutes INPUT A and INPUT B for priority override. Pages can still be made from the PAGE INPUT. The AUX INPUT is summed to MONO. AUX INPUT does not have any gain adjustment, therefore, all gain adjustments must be done from the external source device.
- ❻ **INPUT A/B Switch** - Selects either INPUT A or INPUT B on the rear panel when the rear panel A/B SELECT DIP switch is set to FRONT.
- ❼ **TREBLE/BASS Controls** - Allows tonal adjustments of both outputs simultaneously. These are 1st order shelving filters that provide a ± 6 dB adjustment at 7 kHz and above (TREBLE) and 100 Hz and below (BASS). They have a slope of approximately 6 dB/octave.
- ❽ **MASTER LEVEL Control** - Controls the overall system volume for both the loudspeakers and the AUX OUTPUT when the AUX OUTPUT DIP switch is set to VARIABLE. If the AUX OUTPUT DIP switch is set to FIXED, the AUX OUTPUT maintains maximum level.

Note: When using a REMOTE volume connection, the front panel MASTER LEVEL control becomes disabled. See "Remote Control Connections" on page 26 for more details.

IZA 2120-HZ Rear Panel

Figure 5. FreeSpace IZA 2120-HZ amplifier rear panel

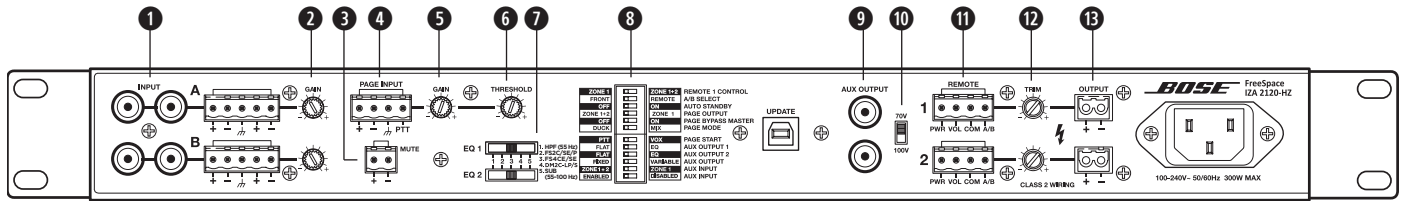

- ❶ **INPUT A/B** - Balanced and unbalanced line-level input connectors. Each input is summed to mono.
- ❷ **INPUT GAIN** - Allows for 0 dB to -30 dB of adjustment to each INPUT A/B.
- ❸ **MUTE** - Contact closure connection that upon trigger (short) will mute all outputs (including AUX OUTPUT).
- ❹ **PAGE INPUT** - Euroblock mic/line input that supports dynamic microphones with voice activation (VOX) or a trigger contact closure for use with push-to-talk (PTT) microphones.
- ❺ **PAGE INPUT GAIN** - Allows for 0 dB to +50 dB of gain control of PAGE INPUT signal.
- ❻ **PAGE INPUT THRESHOLD** - Adjusts the level at which the VOX PAGE INPUT signal causes other inputs to be lowered. A 10 dB adjustment range lifts the page trigger level away from the noise floor to prevent false triggers. At minimum setting, a -70 dBu signal will trigger a VOX page. At maximum setting, a -60 dBu signal will trigger a VOX page. When in PTT page mode this adjustment is not active.
- ❼ **EQ** - Provides loudspeaker equalization presets: HPF (55 Hz), FreeSpace FS2C/SE/P, FS4CE/SE, and DesignMax DM2C-LP/S, SUB (55-100 Hz). The HPF (55 Hz) is equivalent to a flat setting. Use this setting for loudspeakers that are not Bose or that do not require EQ.
- ❽ **DIP Switches** - A bank of switches to set the amplifier configuration. All switches set to the left position is the standard configuration.
 - **REMOTE 1 Control** - Sets the REMOTE 1 input to control both outputs (or zones) simultaneously (ZONE 1+2), or allows each REMOTE input to control its own output (ZONE 1). Each remote has independent A/B selection capability. If only one remote is being used, then this switch must be set to ZONE 1+2.
 - **A/B SELECT** - Determines if A/B inputs are selected by the front panel INPUT A/INPUT B switch (FRONT) or the rear panel remote control input (REMOTE).
 - **AUTO STANDBY** - If enabled (ON) the amplifier will go into standby mode after twenty minutes without an input signal. If in standby mode and an audio signal is detected, the amplifier will automatically wake and amplify audio within 0.7 seconds. The OFF position disables the feature.
 - **PAGE OUTPUT** - Paging can be set to occur in ZONE 1 only or both zones, ZONE 1+2.
 - **PAGE BYPASS MASTER** - Sets the paging volume to follow the front panel MASTER LEVEL setting (OFF) or to output maximum volume (ON). The PAGE INPUT GAIN adjustment is available in either mode. Use this feature if the output volume is too low to hear a page.
 - **PAGE MODE** - Sets the amplifier to mix paging (MIX) with the selected input source or to duck the input source (DUCK) when paging is activated.
 - **PAGE START** - Determines if paging is to be activated by a push-to-talk (PTT) stimulus or voice stimulus (VOX).
 - **AUX OUTPUT 1 (White)** - Determines if auxiliary output 1 will either have no EQ adjustment (FLAT) or an EQ adjustment determined by the EQ 1 slide switch position (EQ).
 - **AUX OUTPUT 2 (Red)** - Determines if auxiliary output 2 will either have no EQ adjustment (FLAT) or an EQ adjustment determined by the EQ 2 slide switch position (EQ).
 - **AUX OUTPUT** - Sets the auxiliary output level to either follow the front panel MASTER LEVEL control setting (VARIABLE), or to the maximum output level (FIXED).
 - **AUX INPUT (ZONE 1+2 / ZONE 1)** - The auxiliary input source can either be output into zone one only or both zones.
 - **AUX INPUT (ENABLED / DISABLED)** - Enables (ENABLED) or disables (DISABLED) the auxiliary input. If enabled, inserting a cable into the auxiliary input will mute INPUT A and B.
- ❾ **AUX OUTPUT** - Variable or fixed, unbalanced line-level output signal for use with ZA zone amplifiers or for routing the signal to additional audio equipment.
- ❿ **70V/100V** - Changes the outputs from 70V to 100V.
- ⓫ **REMOTE** - Input connector for either a ControlCenter CC-2 zone controller for volume control and A/B source selection or a ControlCenter CC-1 zone controller for volume control only.
- ⓬ **OUTPUT 1/OUTPUT 2 TRIM** - Allows for up to 40 dB attenuation of the individual loudspeaker outputs relative to the master level.
- ⓭ **OUTPUT** - Two inverted 2-pin Euroblock connectors for loudspeaker connections. Outputs are not bridgeable.

FreeSpace® ZA 2120-LZA/HZA

ZA 2120-LZA/HZA Front Panel

Figure 6. FreeSpace ZA 2120-LZA/HZA amplifier front panel

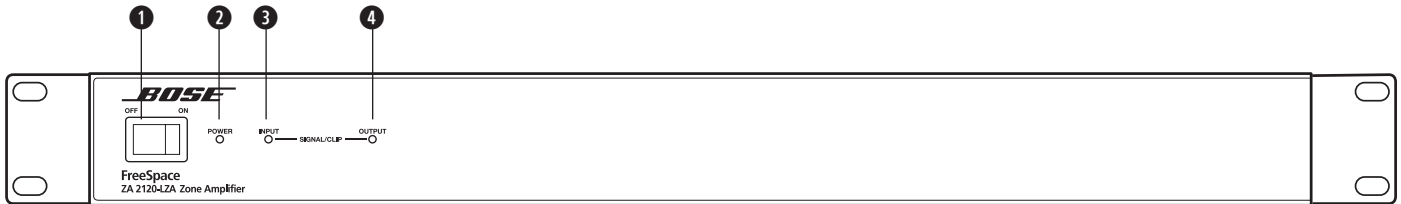

- ❶ **POWER Switch** - ON/OFF AC power.
- ❷ **POWER LED** - Solid blue LED indicates the unit is ON. Blinking blue LED indicates the unit is in standby mode.
- ❸ **INPUT SIGNAL LED** - LED is green from -37 dBu to 11 dBu, LED goes red over 11 dBu.
- ❹ **OUTPUT LIMIT LED** - LED is green from -46 dBFS to -2 dBFS, approximately 80 W per channel. For each output, 120 watts is 0 dBFS.

ZA 2120-LZA/HZA Rear Panel

Figure 7. FreeSpace ZA 2120-HZA amplifier rear panel

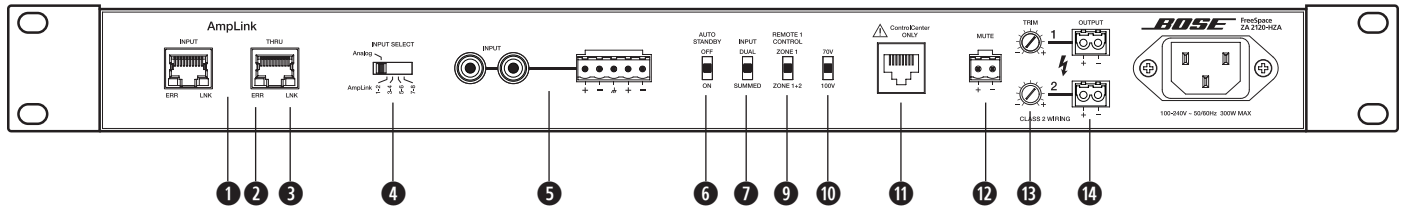
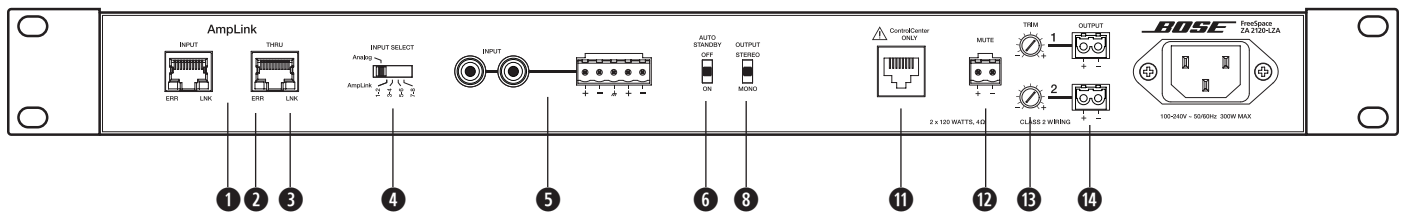

Figure 8. FreeSpace ZA 2120-LZA amplifier rear panel



1 AmpLink - INPUT RJ-45 connector that receives up to the first 8 digital audio channels from a Bose® AmpLink product. The amp also supports a THRU path for daisy-chaining those 8 digital audio channels to other Bose AmpLink products at a maximum distance of 10 m between products.

CAUTION: Shielded EIA/TIA 568B straight CAT 5 cable, or equivalent, is required for proper AmpLink operation. Unshielded cable is not supported and may cause AmpLink audio to operate improperly. Do NOT connect either RJ-45 port to an Ethernet-based network.

2 AmpLink ERR LED - Solid yellow indicates muted audio from the mute connector. Blinking yellow indicates an error, which will also mute the audio.

3 AmpLink LNK LED - Solid green indicates normal operation.

4 INPUT SELECT - Switch selects if analog or AmpLink audio inputs are used. The default state is analog. Only switch settings when the amplifier is powered off.

5 ANALOG INPUT - balanced and unbalanced line-level input connectors.

6 AUTO STANDBY - If enabled (ON), the amplifier will go into standby mode after twenty minutes without an input signal. If in standby mode and an audio signal is detected, the amplifier will automatically wake and amplify audio within 0.7 seconds. The OFF position disables the feature.

7 INPUT - The input can be set to either DUAL mono inputs or SUMMED to one mono input.

8 OUTPUT - The output can be set to STEREO or MONO.

9 REMOTE 1 Control - Sets the REMOTE 1 input to control both outputs (or zones) simultaneously (ZONE 1+2), or allows each REMOTE input to control its own output (ZONE 1). If only one remote is being used, then this switch must be set to ZONE 1+2.

10 70V/100V - Sets the outputs 70V or 100V.

11 CONTROLCENTER - RJ-45 input connector for the CC-1 ControlCenter zone controller, or the CV41 if connecting to two non-ganged CC-1s to the ZA 2120-HZA. If the two CC-1s are ganged together, then the CV41 is not needed.

CAUTION: Do NOT connect this RJ-45 port to an Ethernet-based network.

12 MUTE - Contact closure connection that upon trigger (short) will mute all outputs.

13 OUTPUT TRIM - Allows for up to 40 dB attenuation of each loudspeaker output.

14 OUTPUT - Two inverted 2-pin Euroblock connectors for loudspeaker connections. Outputs are not bridgeable.

Installation

Importance of Proper Ventilation

For placement of the amplifier, keep the following in mind:

- Make sure that air can circulate freely from left to right for adequate ventilation. There are vents on the sides.
- The temperature of the rack should be controlled to ensure that amplifiers are not exposed to ambient temperatures exceeding 40° C (104° F).
- Do not cover or block amplifier vents.
- Do not place the amplifier in an enclosed space, such as a cabinet.
- Make sure the chassis is protected from heat and kept away from direct heat sources, such as heating vents and radiators.



CAUTION: Do not allow the chassis to exceed the maximum operating temperature of 40°C (104°F). Be aware of conditions in an enclosed rack that may increase the temperature above room-ambient conditions. If the amplifier becomes too hot, it will go into a thermal protection mode and mute all outputs.

Rack Mounting

FreeSpace® amplifiers are designed to fit standard 19-inch (48 cm) rack equipment, occupying 1 rack-unit (RU) in height, requiring a mounting depth of 12.2 inches (30.9 cm) from the front rack rail. Use four fasteners with washers (not supplied) to mount the amplifier front panel rack ears to the equipment rack rails.



CAUTION: Only use the mounting hardware recommended by the rack manufacturer.

Removing Rack-Mount Ears

Rack-mount ears can be removed by removing the three screws from each rack-mount ear.

Figure 9. Removing the rack-mount ears

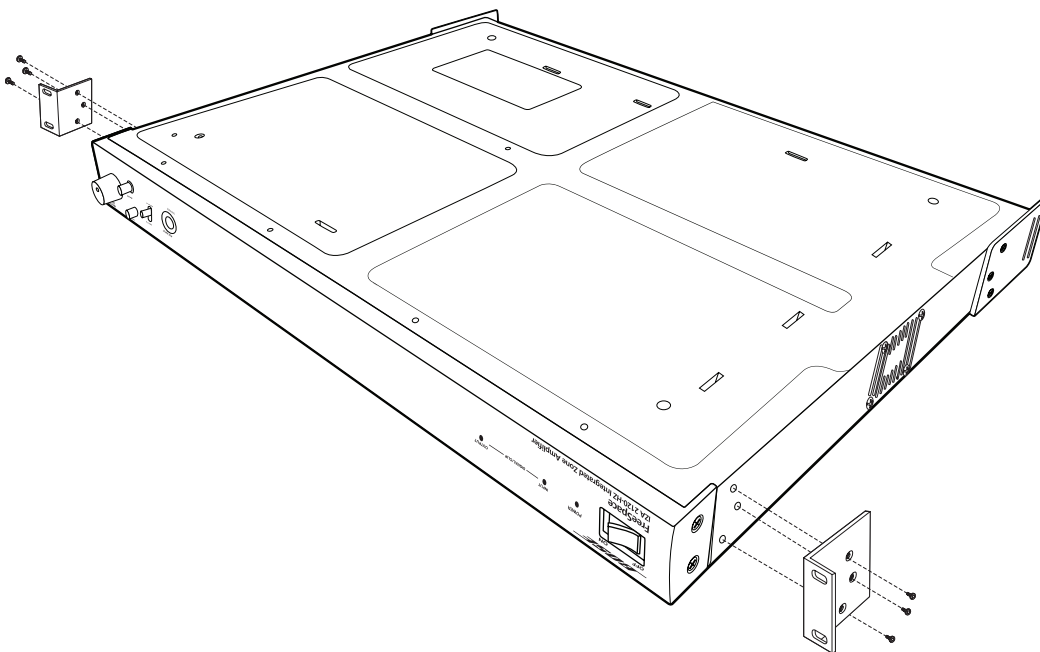

Placing on a Flat Surface

The amplifier can be placed on a flat, stable surface like a table, counter, or shelf. The rack-mount ears can be removed and plastic feet (included with the amplifier) can be installed to protect the surface area and prevent the chassis from sliding.

Note: When installing the amplifier in an office, conference room, or classroom, carefully place it in a way that minimizes the audible affects of the internal cooling fan of the amplifier. It is recommended to place the amplifier below ear level, in a corner, with the fan inlet (left side) pointing away from the seating area.

Installing the Feet on the Amplifier

The included feet are comprised of two parts: a foot and a pin.

1. Place the amplifier upside-down on a flat, level surface on a protective covering to avoid scratching the top of the chassis.
2. Insert the four feet into the four holes on the bottom of the chassis.
3. Insert a pin into the hole on the foot.
4. Press down on the pin until the foot locks into place. Repeat for all four feet.

Figure 10. Installing the feet into the bottom of the amplifier

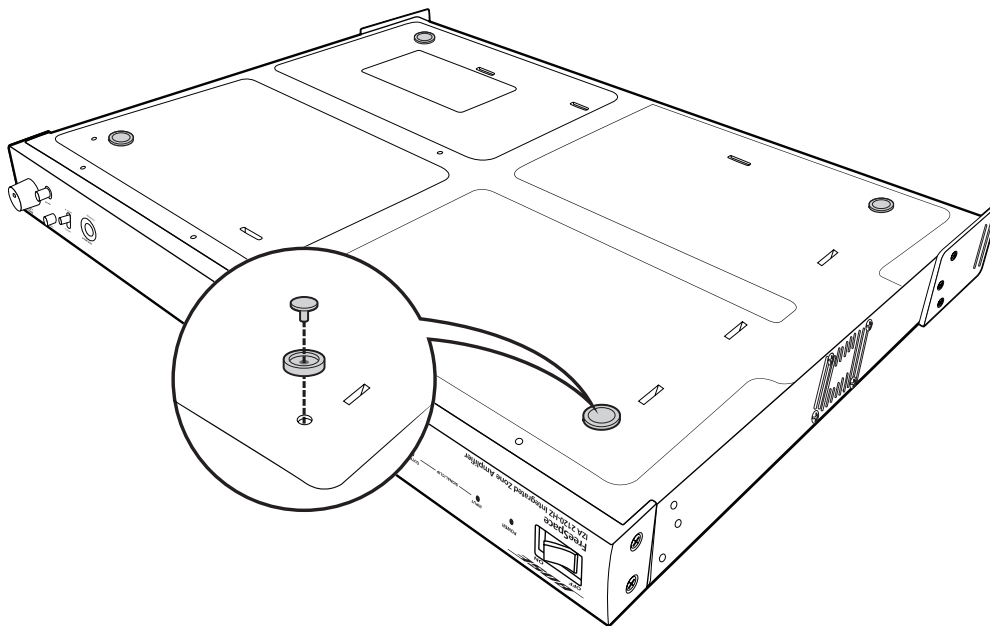

Stacking Units

One amplifier can be stacked on top of another when there is limited space available on a table, counter, or shelf.

Figure 11. Stacking two FreeSpace amplifiers

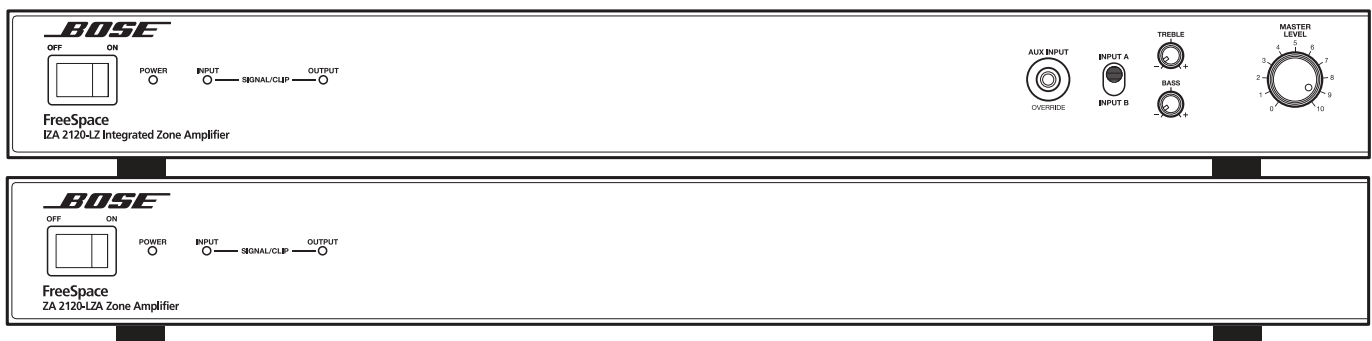

Remote Volume Control

Connecting an Amplifier to a ControlSpace® Engineered Sound Processor

The balanced inputs of the IZA 2120-LZ/HZ and ZA 2120-LZA/HZA can be used to easily connect to the balanced outputs of a ControlSpace engineered sound processor.

Figure 12. Connecting a FreeSpace amplifier to a ControlSpace ESP

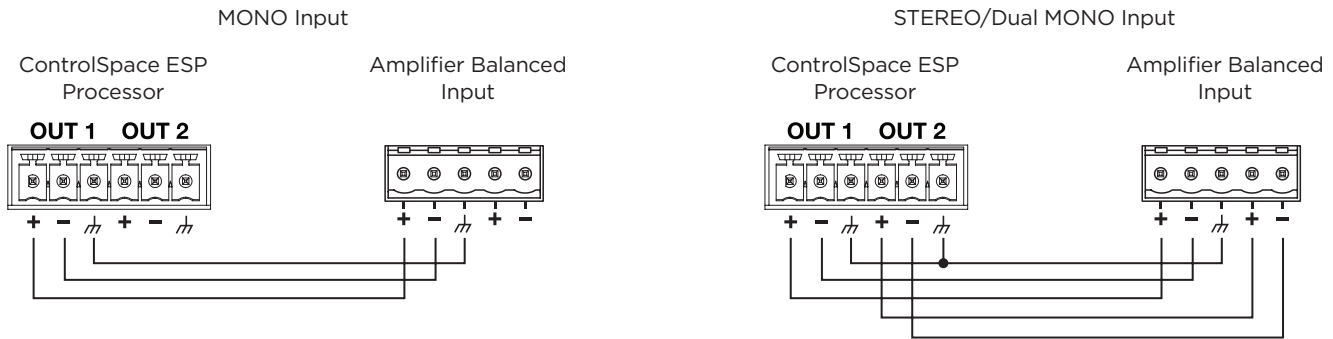

Page Input Connections

The PAGE INPUT is a mic/line input with a trigger contact closure. This input signal is routed to all outputs (including AUX OUT) when the trigger is detected. This is designed for push-to-talk paging microphones and telephone paging systems. In VOX mode a dynamic microphone is also supported. See the diagram below for input wiring configurations. Use the included 4-pin Euroblock.

Figure 13. Page Input wiring connections

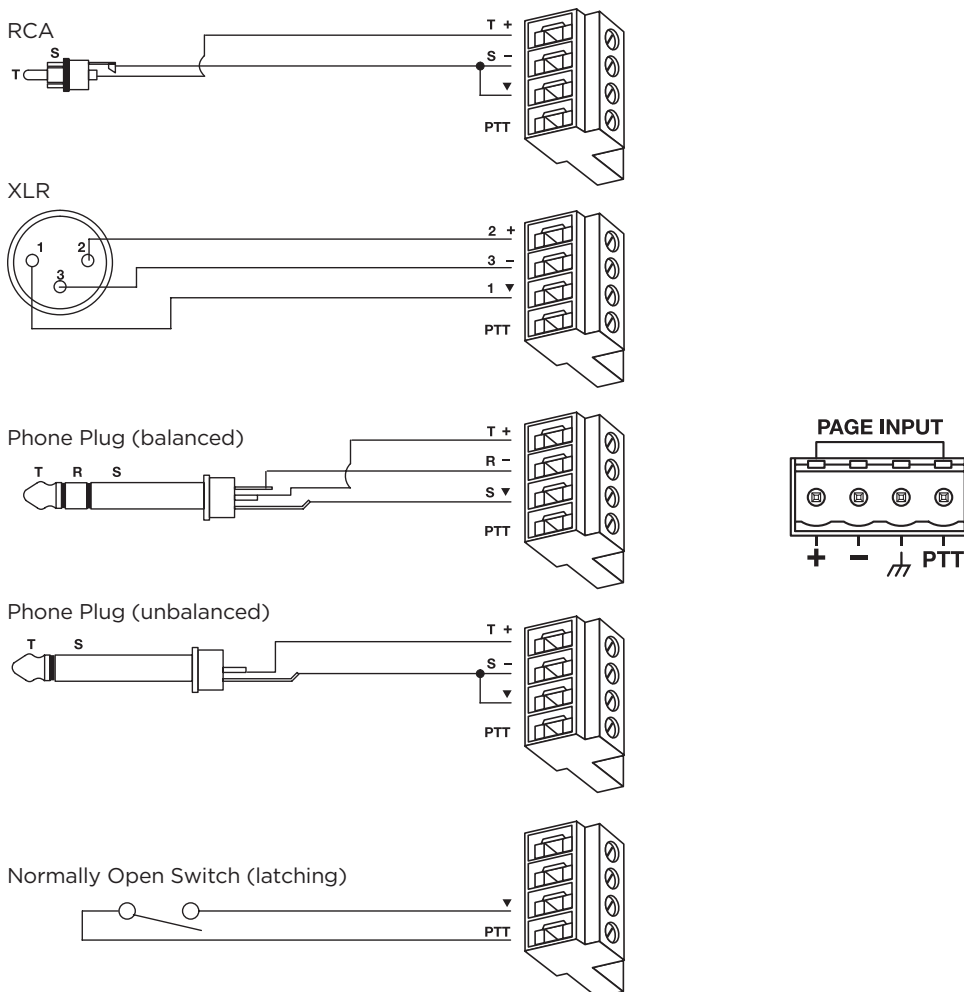

Remote Control Connections

Figure 14. Volume controllers for use with FreeSpace® amplifiers

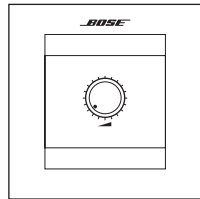

Bose® Volume Control User Interface is for use when only volume control is required.

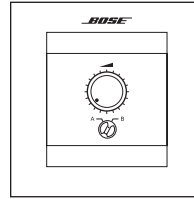

Bose® Volume Control with A/B Select User Interface is for use in Stereo Select Mode or Dual Mono Select Mode when an output provides audio from more than one input source.

Remote volume and source selection control

The amplifier is designed to work with the Bose® volume control A/B switch user interface accessory (PC 041967), or the volume control user interface accessory (PC 041966). The REMOTE connector on the rear panel of the amplifier is labeled to match the connector on the user interface. Use the included 4-pin Euroblock. See the appropriate Bose volume control user interface install guide for more details.

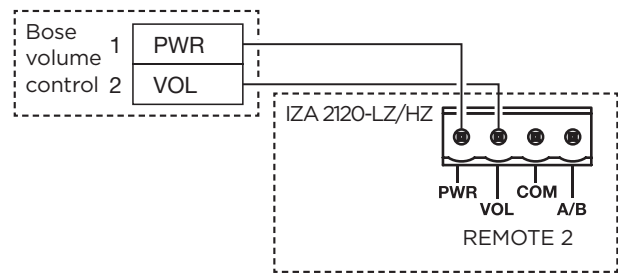
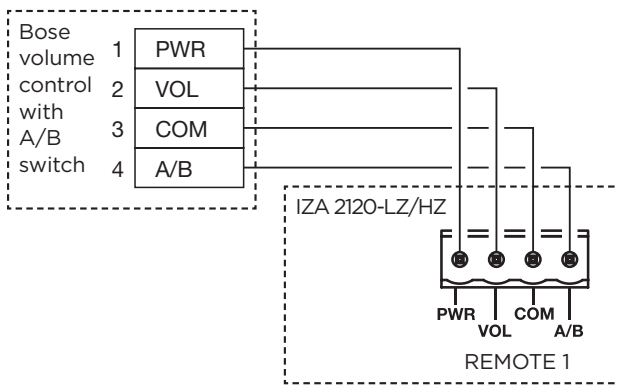

IZA 2120-HZ remote configuration examples

Configuration example #1:

REMOTE 1 can be a Bose volume control with A/B switch user interface accessory (PC 041967). REMOTE 1 will control the level and source selection of both outputs simultaneously. This configuration requires setting the REMOTE 1 CONTROL DIP switch to ZONE 1+2 and the A/B SELECT DIP switch to REMOTE. If only one remote is being used, this switch must be set to ZONE 1_2. If this switch is set to ZONE 1, the REMOTE input will not operate, and front panel controls will be active.

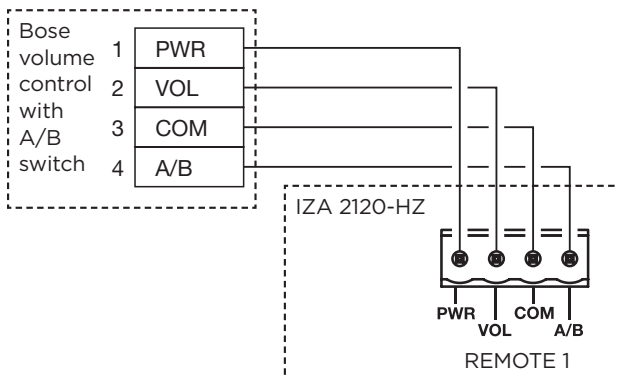

DIP switch settings



Configuration example #2:

REMOTE 1 and REMOTE 2 can be a Bose volume control with A/B switch user interface accessory (PC 041967) accessory. REMOTE 1 will control the level and source selection of output one and REMOTE 2 will control the level and source selection of output two. This configuration requires setting the REMOTE 1 CONTROL DIP switch to ZONE 1 and the A/B SELECT DIP switch to REMOTE.

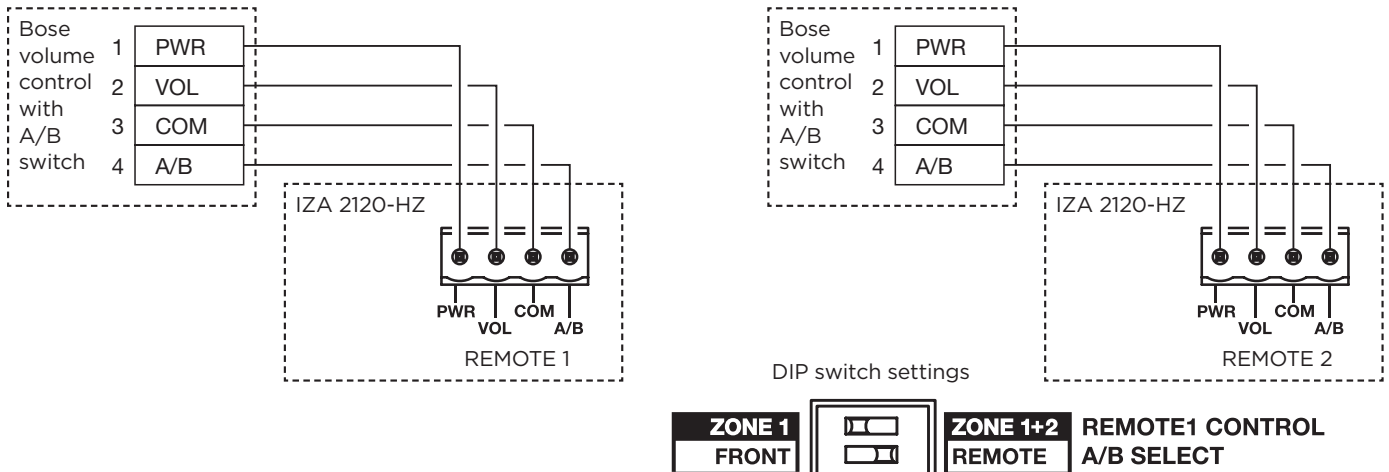

Configuration example #3

REMOTE 1 can be a Bose volume control with A/B switch user interface accessory (PC 041967) and REMOTE 2 can be a volume control user interface accessory (PC 041966). In this configuration, REMOTE 1 controls the level of output one and the source selection for both outputs. REMOTE 2 controls the level for output two. The A/B pin from REMOTE 1 needs to be jumpered with wire to the A/B pin on REMOTE 2. This configuration requires setting the REMOTE 1 CONTROL DIP switch to ZONE 1 and the A/B SELECT DIP switch to REMOTE. If the A/B jumper wire is not connected, output two will default to amplifying input B constantly. If output two is to amplify input A constantly, the A/B pin of REMOTE 2 needs to be jumpered to the COM pin. This configuration also works with the remote types reversed with a volume control user interface accessory (PC 041966) on REMOTE 1 and a volume control with A/B switch user interface accessory (PC 041967) on REMOTE 2.

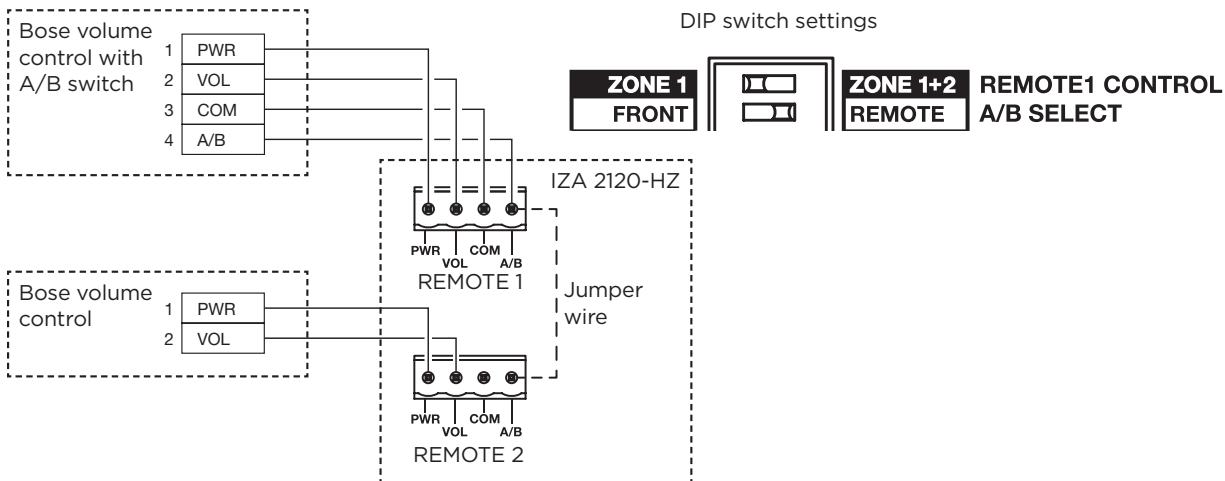

Configuration example #4:

REMOTE 1 and REMOTE 2 can be a volume control user interface accessory (PC 041966). In this configuration, REMOTE 1 controls the level of output one and REMOTE 2 controls the level for output two. A/B source selection for both outputs is simultaneously controlled by the front panel switch. This configuration requires setting the REMOTE 1 CONTROL DIP switch to ZONE 1 and the A/B SELECT DIP switch to FRONT.

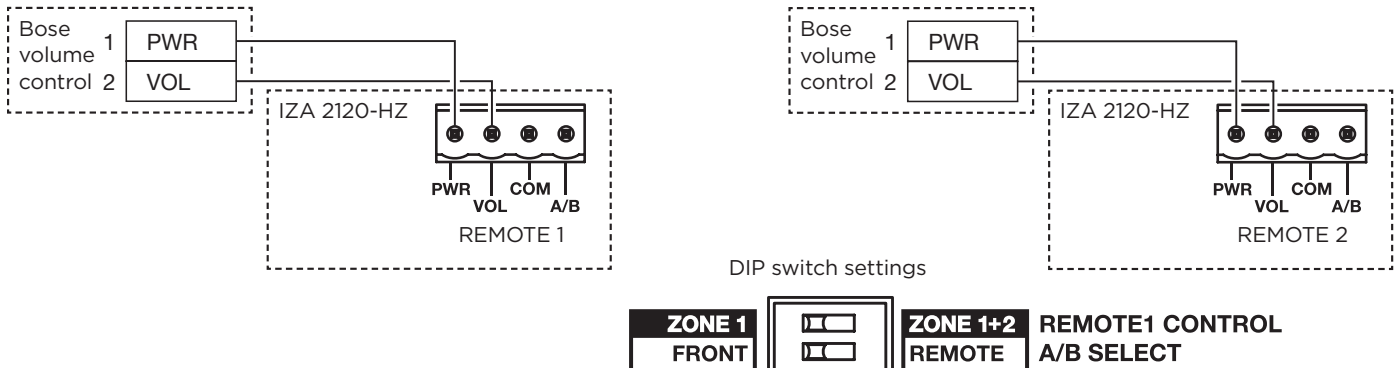

Configuration example #5:

REMOTE 1 can be a volume control user interface accessory (PC 041966). In this configuration, REMOTE 1 controls the level of both outputs simultaneously. A/B source selection for both outputs is simultaneously controlled by the front panel switch. This configuration requires setting the REMOTE 1 CONTROL DIP switch to ZONE 1+2 and the A/B SELECT DIP switch to FRONT.

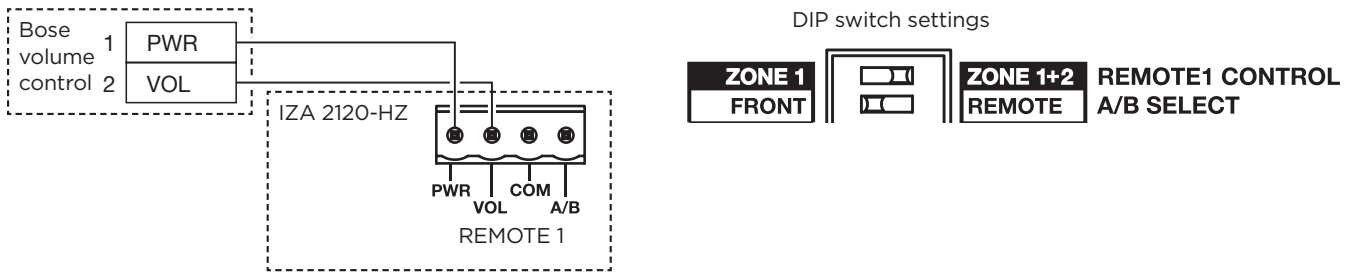

Remote Connections to Zone Amplifiers

Remote volume control

The zone amplifiers are designed to work with the Bose® volume control user interface accessory (PC 041966). The REMOTE connector on the rear panel of the amplifier is labeled to match the connector on the user interface. Use the included 2-pin Euroblock. See the Bose volume control user interface accessory install guide for more details.

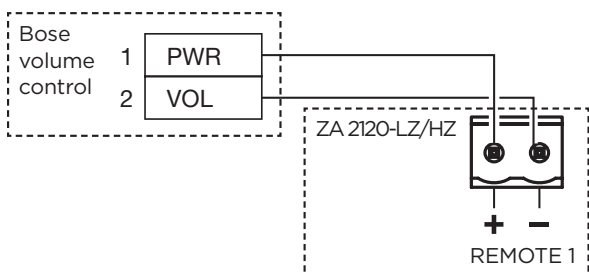

ZA 2120-HZ remote configuration examples

Configuration example #1:

REMOTE 1 can be a Bose® volume control user interface accessory (PC 041966). REMOTE 1 will control the level of both outputs simultaneously. This configuration requires setting the REMOTE 1 CONTROL switch to ZONE 1+2. If only one remote is being used, this switch must be set to ZONE 1+2. If this switch is set to ZONE 1, the REMOTE will not operate.

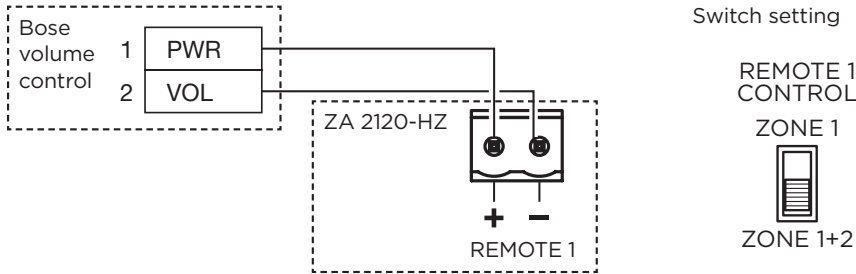

Configuration example #2:

REMOTE 1 and REMOTE 2 can be a volume control user interface accessory (PC 041966). In this configuration, REMOTE 1 controls the level of output one and REMOTE 2 controls the level for output two. This configuration requires setting the REMOTE 1 CONTROL switch to ZONE 1.

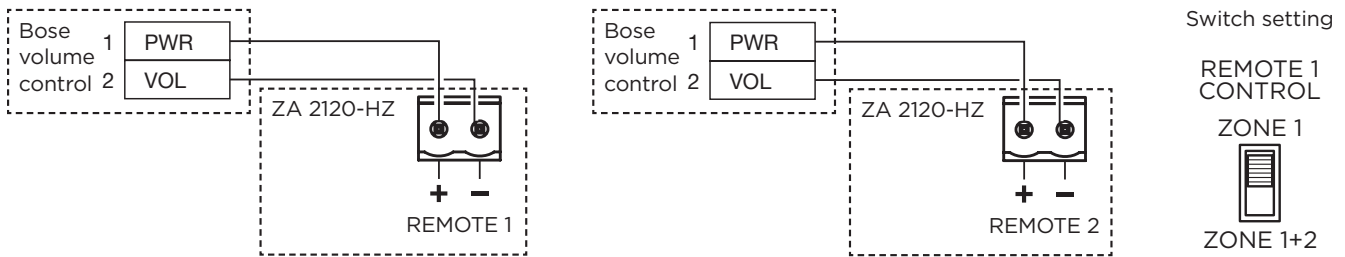

Remote input functionality

The amplifier also can be controlled with a linear taper 10k ohm potentiometer (fully CCW = 0 ohm, fully CW = 10k ohm) and SPDT switch. When the SW1 switch is set to short the A/B pin to the COM pin, the amplifier switches to input A. When the SW1 switch is set to make the A/B pin open, the amplifier switches to input B.

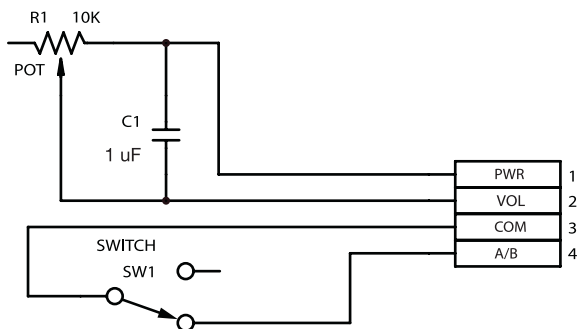

Connecting a ControlCenter Zone Controller

Figure 15. ControlCenter CC-1 and CC-2 Zone Controllers

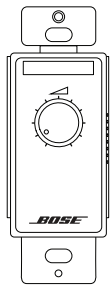

Bose® ControlCenter CC-1 Zone Controller
provides volume control only.

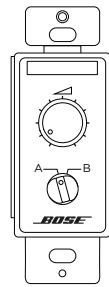

Bose® ControlCenter CC-2 Zone Controller
provides volume control and A/B source selection.

Connecting the CC-1 to a FreeSpace® Amplifier

One CC-1

Connect one CC-1 zone controller to FreeSpace® amplifier models IZA 2120-LZ/HZ or ZA 2120-LZ/HZ. DIP switch settings are the same when connecting to the ZA 2120-LZA/HZA.

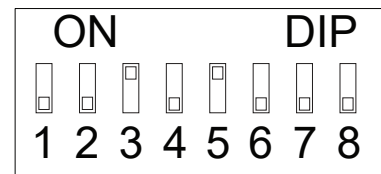
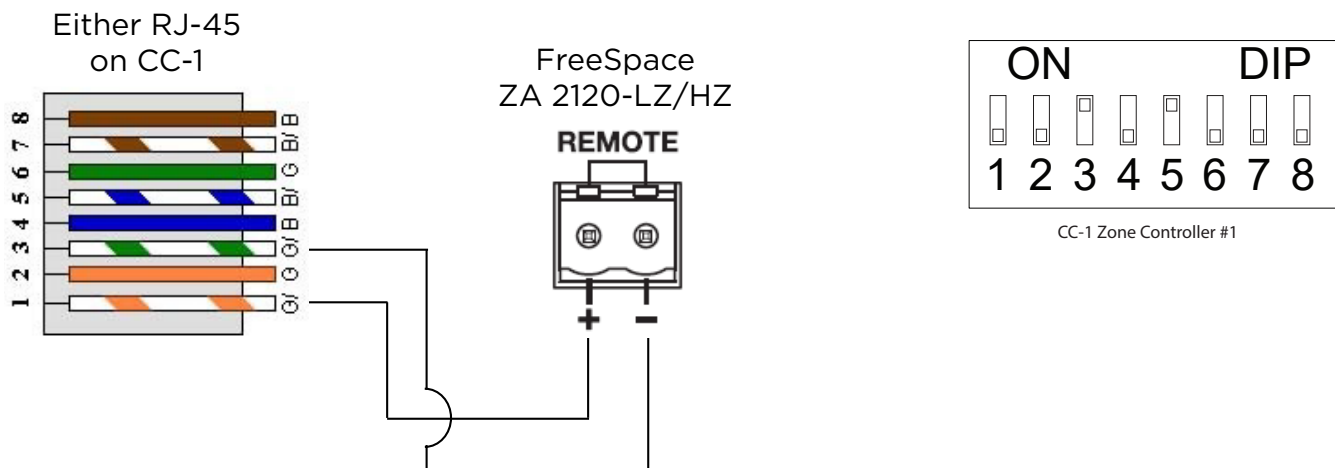
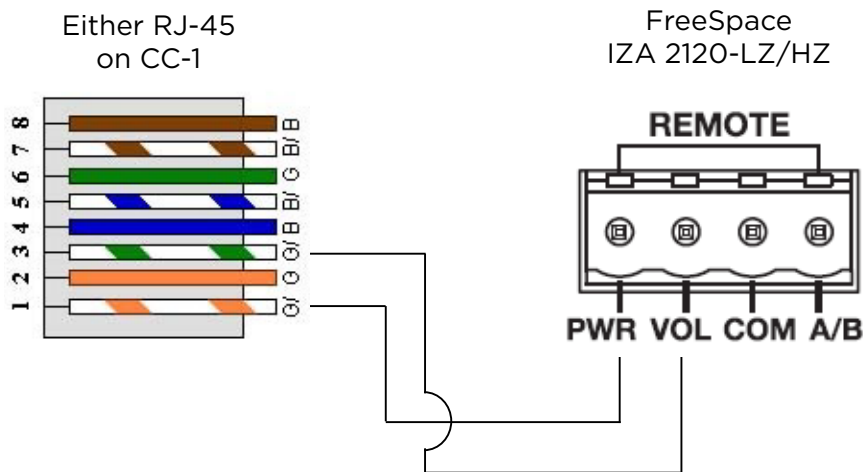

CC-1 Zone Controller #1

Two CC-1s

Connect two ganged CC-1 zone controllers to FreeSpace® amplifier models IZA 2120-HZ or ZA 2120-HZ. DIP switch settings are the same when connecting to the ZA 2120-HZA.

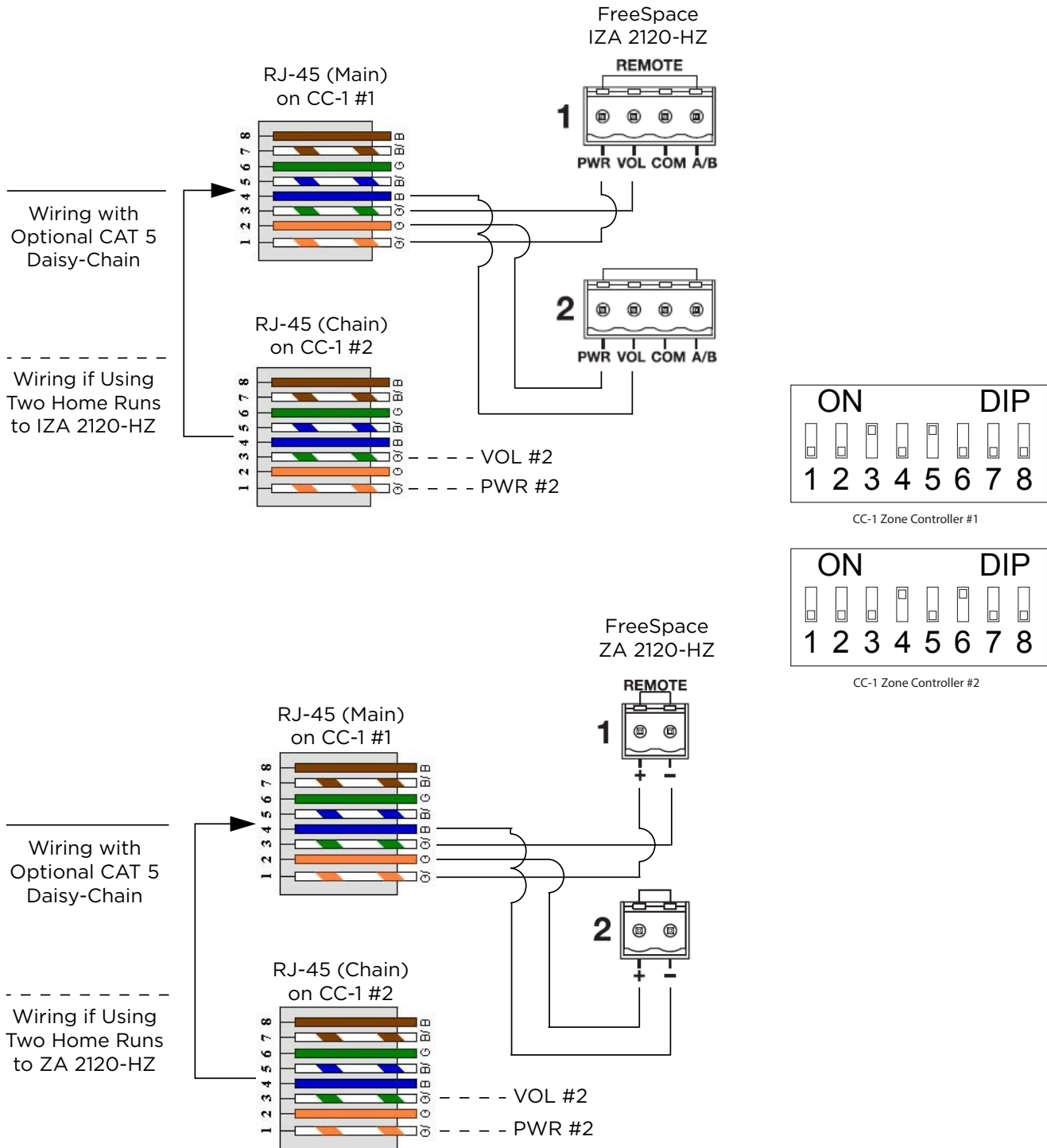

Connecting the CC-2 to a FreeSpace® Amplifier

One CC-2

Connect one CC-2 zone controller to FreeSpace® amplifier models IZA 2120-LZ/HZ.

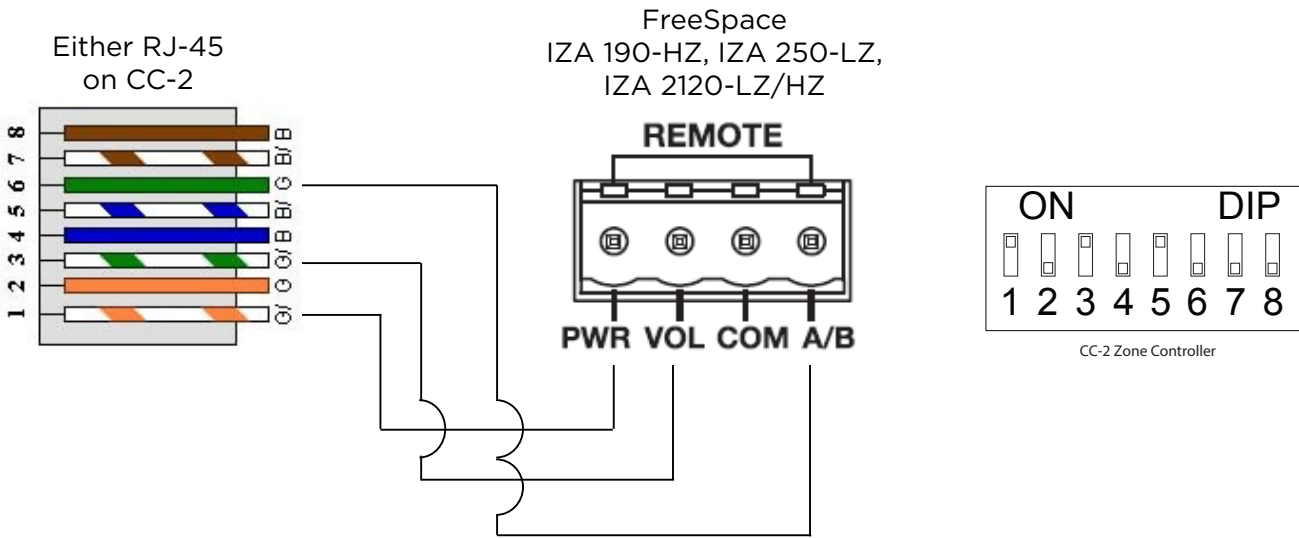

Two CC-2s

Connect two ganged CC-2 zone controllers to FreeSpace® amplifier model IZA 2120-HZ.

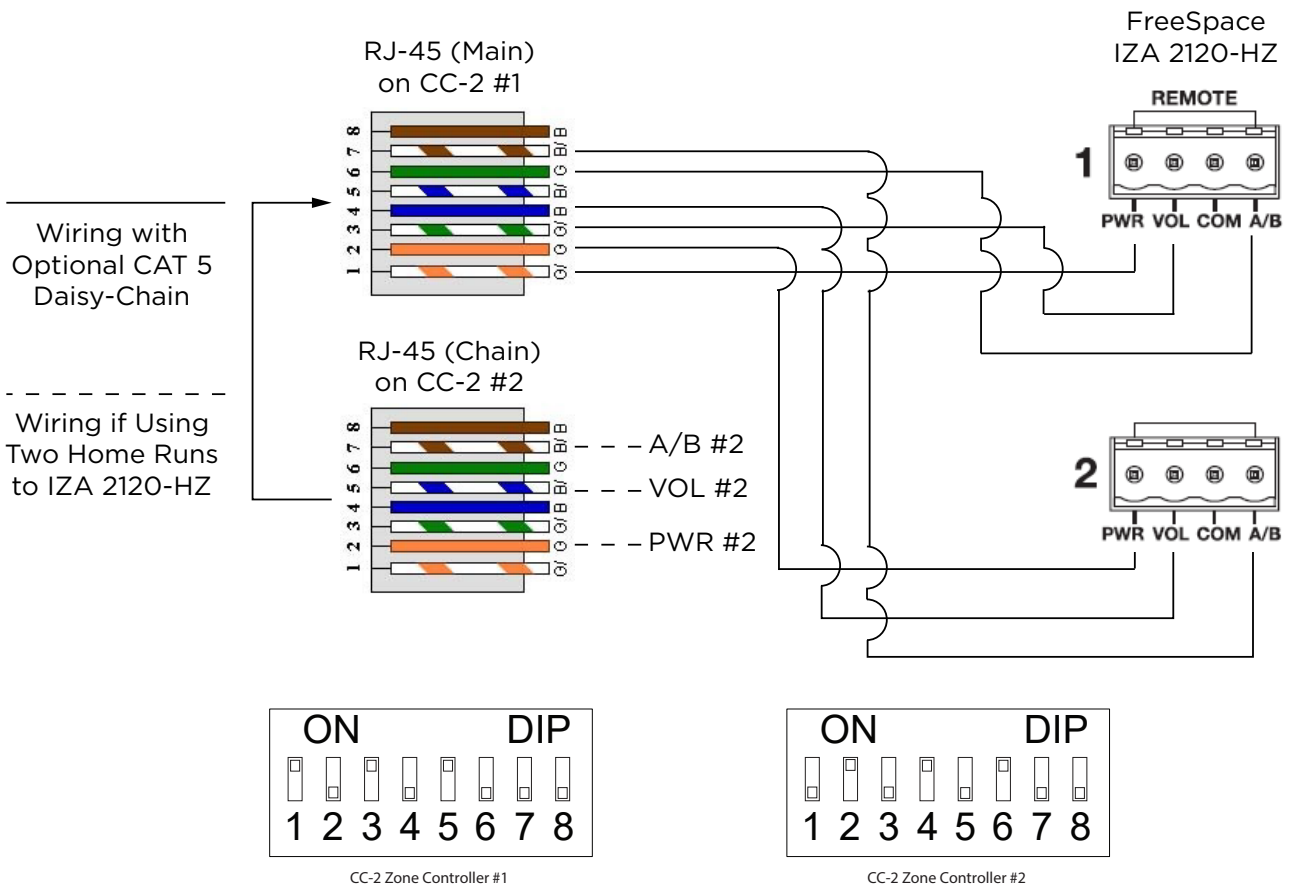

Mute with standard contact closure

The amplifier is designed to mute all outputs (including AUX OUT) when the MUTE contacts are shorted together. Use the included 2-pin Euroblock.

Figure 16. Amplifier mute contact closure

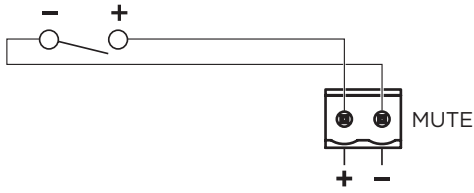

Loudspeaker Usage

This table shows the maximum quantity of loudspeakers supported by each IZA 2120-HZ or ZA 2120-HZA amplifier output for each loudspeaker tap setting. The data is based on the maximum output of 120 watts per each amplifier output. **Do not exceed 120 W per output.**

High-impedance loudspeakers per amplifier output

| | Max. Qty. of Loudspeakers Per Output / Tap Setting | | | | |
|--|--|-----------|-----------|----------|---------|
| FreeSpace FS2C/SE/P | 120 / 1W | 60 / 2W | 30 / 4W | 15 / 8W | 7 / 16W |
| FreeSpace FS4CE/SE | 48 / 2.5W | 24 / 5W | 12 / 10W | 6 / 20W | 3 / 40W |
| DesignMax DM2C-LP/S | 100 / 1.2W | 52 / 2.3W | 26 / 4.5W | 13 / 9W | — |
| DesignMax DM3C/SE | 40 / 3W | 20 / 6W | 10 / 12W | 4 / 25W | — |
| DesignMax DM8C-Sub/DM10S-Sub | 6 / 20W | 3 / 40W | 1 / 80W | 0 / 150W | — |
| FreeSpace 3 Acoustimass Module I or II | 4 / 25W | 2 / 50W | 1 / 100W | 0 / 200W | — |

Expanding an IZA System with a ZA Amplifier

Expansion Overview

The FreeSpace® zone amplifier makes system expansion easy. When a system design requires more loudspeakers than the FreeSpace IZA 2120-LZ/HZ integrated zone amplifier can support, a FreeSpace zone amplifier can be connected to provide additional power or zones.

When connected together, the IZA 2120-LZ/HZ and any zone amplifier (ZA 2120-LZA/HZA, ZA 250-LZ, ZA 190-HZ) can operate together as one system, sharing the same music and paging sources. The IZA 2120-LZ/HZ amplifier operates as the master of the zone amplifier, determining which audio sources will be heard. The overall MASTER LEVEL volume can be controlled by the integrated zone amplifier in one larger zone, or volume control can be distributed in multi-zone installations.

Connecting an IZA 2120-LZ/HZ Amplifier to a ZA 2120-LZA/HZA Amplifier

Using the included RCA cable, connect the AUX OUT of the IZA 2120-LZ/HZ amplifier to the unbalanced INPUT of any zone amplifier.

Figure 17. Connecting an IZA 2120-LZ/HZ to a ZA 2120-LZA/HZA

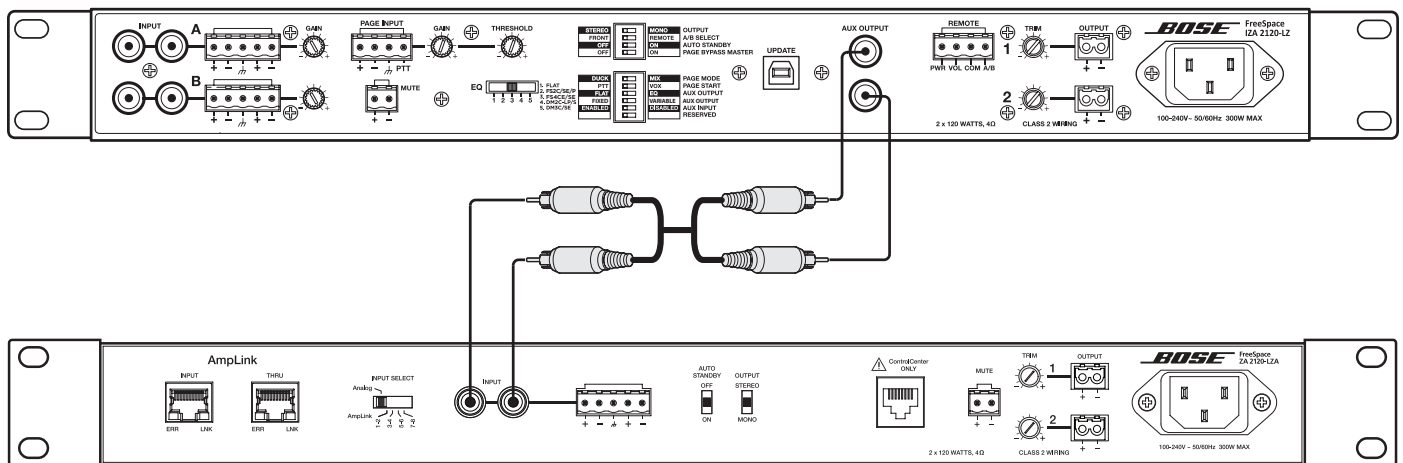

Note: It is recommended that when amplifiers are connected together, that both amplifier AC power cords are plugged into the same AC outlet to reduce potential noise issues.

Line Input Connections

When using a front-end signal processor, or connecting multiple zone amplifiers to an integrated zone amplifier, the included RCA cable may need to be modified. The wiring diagram for the zone amplifier line-level input RCA connectors is provided below.

Figure 18. Zone amplifier line-level input RCA connectors

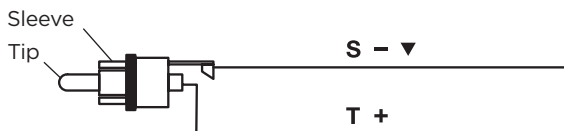

Connecting an IZA 2120-LZ/HZ Amplifier to Multiple Zone Amplifiers

The auxiliary output of the IZA 2120-LZ/HZ can be connected in a star configuration to four zone amplifiers without experiencing signal loss.

Figure 19. Connecting four zone amplifiers using T/S RCA connectors

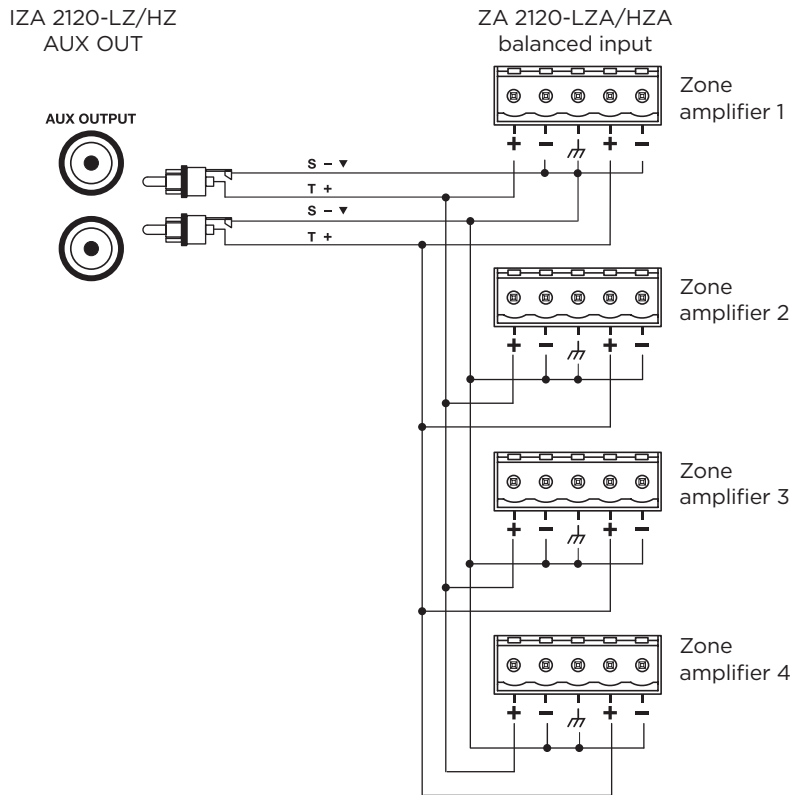
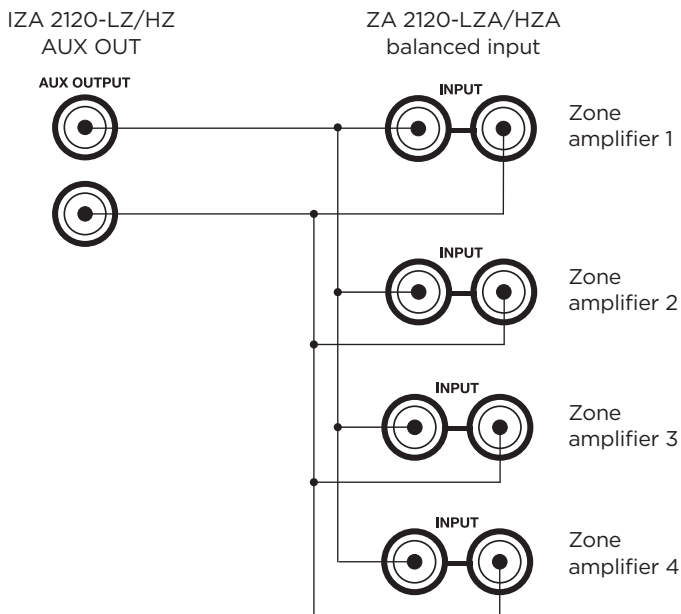

Figure 20. Connecting four zone amplifiers using RCA male stackable connector cables



AC Current Draw and Thermal Dissipation Information

Amplifier rated channel power is 120 W.

| IZA 2120-LZ AC Current Draw and Thermal Dissipation | | | | | | | |
|--|--|-----------------------|-------------------------------|-------------------------------|--------------------------|--------|---------|
| Test Signal & Power Level | Load Configuration (Both IZA channels driven) | Total Audio Output, W | 120 VAC 60 Hz Line Current, A | 230 VAC 50 Hz Line Current, A | Thermal Dissipation, Max | | |
| | | | | | Watts | BTU/hr | kCal/hr |
| Power On, Idling | | 0 | 0.15 | 0.12 | 27 | 92 | 23 |
| 1/8th Rated Power IEC268 Bandlimited Pink Noise 6 dB Crest Factor FS2C/SE/P EQ Enabled | 8Ω/Ch | 15 | 0.30 | 0.18 | 26 | 90 | 23 |
| | 4Ω/Ch | 30 | 0.51 | 0.30 | 39 | 133 | 34 |
| 1/3rd Rated Power IEC268 Bandlimited Pink Noise 6 dB Crest Factor FS2C/SE/P EQ Enabled | 8Ω/Ch | 40 | 0.63 | 0.33 | 36 | 122 | 31 |
| | 4Ω/Ch | 80 | 1.15 | 0.58 | 58 | 198 | 50 |

| IZA 2120-HZ AC Current Draw and Thermal Dissipation | | | | | | | |
|--|--|-----------------------|-------------------------------|-------------------------------|--------------------------|--------|---------|
| Test Signal & Power Level | Load Configuration (Both IZA channels driven) | Total Audio Output, W | 120 VAC 60 Hz Line Current, A | 230 VAC 50 Hz Line Current, A | Thermal Dissipation, Max | | |
| | | | | | Watts | BTU/hr | kCal/hr |
| Power On, Idling | | 0 | 0.19 | 0.13 | 31 | 104 | 26 |
| 1/8th Rated Power IEC268 Bandlimited Pink Noise 6 dB Crest Factor FS2C/SE/P EQ Enabled | 70V/Ch | 30 | 0.56 | 0.30 | 39 | 133 | 34 |
| | 100V/Ch | 30 | 0.60 | 0.31 | 42 | 143 | 36 |
| 1/3rd Rated Power IEC268 Bandlimited Pink Noise 6 dB Crest Factor FS2C/SE/P EQ Enabled | 70V/Ch | 80 | 1.18 | 0.57 | 62 | 210 | 53 |
| | 100V/Ch | 80 | 1.15 | 0.58 | 58 | 198 | 50 |

Amplifier rated channel power is 120 W.

| ZA 2120-LZA, AC Current Draw and Thermal Dissipation | | | | | | | |
|--|--|-----------------------|-------------------------------|-------------------------------|--------------------------|--------|---------|
| Test Signal & Power Level | Load Configuration (Both IZA channels driven) | Total Audio Output, W | 120 VAC 60 Hz Line Current, A | 230 VAC 50 Hz Line Current, A | Thermal Dissipation, Max | | |
| | | | | | Watts | BTU/hr | kCal/hr |
| Power On, Idling | | 0 | 0.15 | 0.11 | 25 | 86 | 22 |
| 1/8th Rated Power IEC268 Bandlimited Pink Noise 6 dB Crest Factor | 8Ω/Ch | 15 | 0.33 | 0.19 | 29 | 98 | 25 |
| | 4Ω/Ch | 30 | 0.52 | 0.28 | 34 | 117 | 30 |
| 1/3rd Rated Power IEC268 Bandlimited Pink Noise 6 dB Crest Factor | 8Ω/Ch | 40 | 0.57 | 0.31 | 31 | 107 | 27 |
| | 4Ω/Ch | 80 | 1.00 | 0.56 | 49 | 167 | 42 |
| ZA 2120-HZA AC Current Draw and Thermal Dissipation | | | | | | | |
| Test Signal & Power Level | Load Configuration (Both IZA channels driven) | Total Audio Output, W | 120 VAC 60 Hz Line Current, A | 230 VAC 50 Hz Line Current, A | Thermal Dissipation, Max | | |
| | | | | | Watts | BTU/hr | kCal/hr |
| Power On, Idling | | 0 | 0.20 | 0.14 | 32 | 110 | 28 |
| 1/8th Rated Power IEC268 Bandlimited Pink Noise 6 dB Crest Factor | 70V/Ch | 30 | 0.50 | 0.30 | 37 | 125 | 32 |
| | 100V/Ch | 30 | 0.60 | 0.30 | 41 | 141 | 36 |
| 1/3rd Rated Power IEC268 Bandlimited Pink Noise 6 dB Crest Factor | 70V/Ch | 80 | 1.10 | 0.60 | 58 | 198 | 50 |
| | 100V/Ch | 80 | 1.10 | 0.60 | 58 | 198 | 50 |

IZA 2120-LZ Specifications

| Power Rating | | | |
|--------------------------------|--|---------------------|-------------------|
| Amplifier Power | 2 x 120 W @ 4 Ω, 2 x 60 W @ 8 Ω | | |
| Audio Performance | | | |
| Frequency Response | 20 Hz - 20 kHz (+0/-3 dB, @ 1 W reference 1 kHz) | | |
| THD+N | ≤ 0.5 % (at rated power) | | |
| Channel Separation (Crosstalk) | ≤ -58 dBu (below rated power, 1 kHz) | | |
| Dynamic Range | 88 dB | | |
| Integrated DSP | | | |
| A/D and D/A Converters | 24-bit / 48 kHz | | |
| Processing Functions | Loudspeaker EQ, Bose® Opti-voice® paging, Dynamic equalization | | |
| Loudspeaker Presets | Flat, FreeSpace FS2C/SE/P, FS4CE/SE, and DesignMax DM2C-LP/S, DM3C/SE | | |
| Audio Latency | 10.4 ms (any input to speaker output or aux output) | | |
| Audio Inputs | | | |
| | Line Inputs | Page Input | Auxiliary Input |
| Input Channels | 2 unbalanced, 2 balanced | 1 balanced mic/line | |
| Connectors | Stereo RCA, 5-pin Euroblock | 4-pin Euroblock | 1/8" (3.5 mm) TRS |
| Input Range | -8 dBu to 22 dBu | -58 dBu to 12 dBu | -60dBu to -1 dBu |
| Adjustment Range | 0 dB to -30 dB | 0 dB to +50 dB | Fixed |
| Input Impedance | 20 kΩ | 2 kΩ | 20 kΩ |
| Maximum Input Level | 22 dBu | 12 dBu | -1 dBu |
| Sensitivity | -8 dBu | N/A | -3 dBu |
| Nominal Input Level | 4 dBu | -38 dBu | -8 dBu |
| Audio Outputs | | | |
| | Amplifier Outputs | Auxiliary Output | |
| Outputs | 2 | 1 unbalanced | |
| Connectors, Output | 2-pin inverted Euroblock | Stereo RCA | |
| Output Impedance | 4 Ω | 150 Ω | |
| Nominal Output Level | 2 x 120 W @ 4 Ω, 2 x 60 W @ 8 Ω | 2 dBu | |
| Indicators and Controls | | | |
| Power LED | Solid blue indicates power is on, blinking blue indicates standby mode | | |
| Input Signal Clip LED | Green indicates input signal is within -37 dBu to 11 dBu, red indicates signal is over 11 dBu, master level set at 5 | | |
| Output Signal Clip LED | Green indicates input signal is within -46 dBFS to -2 dBFS red indicates signal is over -2 dBFS, approximately 80 W/channel, for each output 120 watts is 0 dBFS | | |
| Controls, Front Panel | Power On/Off, Input Select (A/B), Treble/Bass Tone Controls, Master Level | | |
| Controls, Rear Panel | Amplifier Mode DIP switches, Loudspeaker EQ preset selector, Input Gain (A/B/Page), Output trims, Remote | | |
| Electrical | | | |
| Mains Voltage | 100 VAC - 240 VAC (±10%, 50/60 Hz) | | |
| AC Power Consumption | 10.6 W (Standby), 300 W (Max) | | |
| Mains Connector | Standard IEC (C14) | | |
| Maximum Inrush Current | 12.6 Amps (230 VAC / 50 Hz), 6.6 Amps (120 VAC / 60 Hz) | | |
| Overload Protection | High temperature, output short, excessively low or high AC line voltage | | |
| Physical | | | |
| Dimensions | 1.7" H x 19.0" W x 12.8" D (44 mm x 483 mm x 324 mm) | | |
| Shipping Weight | 12.0 lb (5.4 kg) | | |
| Net Weight | 9.0 lb (4.1 kg) | | |
| Cooling System | Single fan creates continuous left-to-right air flow | | |
| General | | | |
| Inputs (Control) | Remote input for CC-1 ControlCenter zone controllers or Volume Control user interface (PC041966); Remote input for CC-2 ControlCenter zone controllers or Volume Control with A/B Select user interface (PC041967); Mute input control via a normally open contact closure | | |

IZA 2120-HZ Specifications

| Power Rating | | | |
|--------------------------------|--|---------------------|-------------------|
| Amplifier Power | 2 x 120 W @ 70/100 V | | |
| Audio Performance | | | |
| Frequency Response | 55 Hz - 20 kHz (+0/-3 dB, @ 1 W reference 1 kHz) | | |
| THD+N | ≤ 0.3 % (at rated power) | | |
| Channel Separation (Crosstalk) | ≤ -58 dBu (below rated power, 1 kHz) | | |
| Dynamic Range | 88 dB | | |
| Integrated DSP | | | |
| A/D and D/A Converters | 24-bit / 48 kHz | | |
| Processing Functions | Loudspeaker EQ, Bose® Opti-voice® paging, Dynamic equalization | | |
| Loudspeaker Presets | HPF (55 Hz), FreeSpace FS2C/SE, FS4C/SE, and DesignMax DM2C-LP/S, DM8C-SUB/FS3B | | |
| Audio Latency | 10.4 ms (any input to speaker output or aux output) | | |
| Audio Inputs | | | |
| | Line Inputs | Page Input | Auxiliary Input |
| Input Channels | 2 unbalanced, 2 balanced | 1 balanced mic/line | 1 unbalanced line |
| Connectors | Stereo RCA, 5-pin Euroblock | 4-pin Euroblock | 1/8" (3.5mm) TRS |
| Input Range | -8 dBu to 22 dBu | -58 dBu to 12 dBu | -60 dBu to -1 dBu |
| Adjustment Range | 0 dB to -30 dB | 0 dB to +50 dB | Fixed |
| Input Impedance | 20 kΩ | 2 kΩ | 20 kΩ |
| Maximum Input Level | 22 dBu | 12 dBu | -1 dBu |
| Sensitivity | -8 dBu | N/A | -3 dBu |
| Nominal Input Level | 4 dBu | -38 dBu | -8 dBu |
| Audio Outputs | | | |
| | Amplifier Outputs | Auxiliary Output | |
| Outputs | 2 | 1 unbalanced | |
| Connectors | 2-pin inverted Euroblock | Stereo RCA | |
| Output Impedance | N/A | 400 Ω | |
| Nominal Output Level | 2 x 120 W @ 70/100 V | 2 dBu | |
| Indicators and Controls | | | |
| Power LED | Solid blue indicates power is on, blinking blue indicates standby mode | | |
| Input Signal Clip LED | Green indicates input signal is within -37 dBu to 11 dBu, red indicates signal is over 11 dBu, master level set to 5 | | |
| Output Signal Clip LED | Green indicates output signal is within -46 dBFS to -2 dBFS, red indicates signal is over -2 dBFS, approximately 80 W/channel, for each output 120 watts is 0 dBFS | | |
| Controls, Front Panel | Power On/Off, Input Select (A/B), Treble/Bass Tone Controls (x2), Master Level | | |
| Controls, Rear Panel | Amplifier Mode DIP switches, Loudspeaker EQ preset selector, Input Gain (A/B/Page), Output trims, Remote (x2) | | |
| Electrical | | | |
| Mains Voltage | 100 VAC - 240 VAC (±10%, 50/60 Hz) | | |
| AC Power Consumption | 13.8 W (Standby), 300 W (Max) | | |
| Mains Connector | Standard IEC (C14) | | |
| Maximum Inrush Current | 12.6 Amps (230 VAC / 50 Hz), 6.6 Amps (120 VAC / 60 Hz) | | |
| Overload Protection | High temperature, output short, excessively low or high AC line voltage | | |
| Physical | | | |
| Dimensions | 1.7" H x 19.0" W x 12.8" D (44 mm x 483 mm x 324 mm) | | |
| Shipping Weight | 12.0 lb (5.4 kg) | | |
| Net Weight | 9.0 lb (4.1 kg) | | |
| Cooling System | Single fan creates continuous left-to-right air flow | | |
| General | | | |
| Inputs (Control) | Remote input for CC-1 ControlCenter zone controllers or Volume Control user interface (PC041966); Remote input for CC-2 ControlCenter zone controllers or Volume Control with A/B Select user interface (PC041967); Mute input control via a normally open contact closure | | |

ZA 2120-LZA Specifications

| Power Rating | | |
|--------------------------------|---|--|
| Amplifier Power | 2 x 120 W @ 4 Ω, 2 x 60 W @ 8 Ω | |
| Audio Performance | | |
| Frequency Response | 20 Hz - 20 kHz (+0/-3 dB, @ 1 W reference 1 kHz) | |
| THD+N | ≤ 0.5 % (at rated power) | |
| Channel Separation (Crosstalk) | ≤ -58 dBu (below rated power, 1 kHz) | |
| Dynamic Range | 88 dB | |
| Audio Inputs | | |
| | Analog | AmpLink |
| Input Channels | 1 unbalanced, 1 balanced | 8 digital |
| Connectors | Stereo RCA, 5-pin Euroblock | RJ-45 (Input) |
| Input Range | -8 dBu to 22 dBu | |
| Input Impedance | 20 kΩ | |
| Maximum Input Level | 22 dBu | |
| Nominal Input Level | 4 dBu | |
| Audio Latency | 1 ms (analog input to loudspeaker output) | 1.5 ms (AmpLink input to loudspeaker output) |
| Audio Outputs | | |
| | Analog | AmpLink |
| Outputs | 2 | 8 digital |
| Connectors | 2-pin inverted Euroblock | RJ-45 (Thru) |
| Nominal Output Level | 2 x 120 W @ 4 Ω, 2 x 60 W @ 8 Ω | |
| Indicators and Controls | | |
| Power LED | Solid blue indicates power is on, blinking blue indicates standby mode. | |
| Input Signal Clip LED | Green indicates input signal is within -37 dBu to 11 dBu, red indicates signal is over 11 dBu. | |
| Output Signal Clip LED | Green indicates output signal is within -46 dBFS to -2 dBFS, red indicates signal is over -2 dBFS, approximately 80 W/channel, for each output 120 watts is 0 dBFS. | |
| AmpLink ERR LED | Solid yellow indicates muted audio from the mute connector. Blinking yellow indicates an error, which will also mute the audio. | |
| AmpLink LNK LED | Solid green indicates normal operation. | |
| Controls, Front Panel | Power On/Off | |
| Controls, Rear Panel | Auto Standby: On/Off switch, Output: Stereo/Mono switch, Mute, Output trims, Remote RJ-45 | |
| Electrical | | |
| Mains Voltage | 100 VAC - 240 VAC (±10 %, 50/60 Hz) | |
| AC Power Consumption | 10.6 W (Standby), 300 W (Max) | |
| Mains Connector | Standard IEC (C14) | |
| Maximum Inrush Current | 12.6 Amps (230 VAC / 50 Hz), 7.8 Amps (120 VAC / 60 Hz) | |
| Overload Protection | High temperature, output short, excessively low or high AC line voltage | |
| Physical | | |
| Dimensions | 1.7" H x 19.0" W x 12.8" D (44 mm x 483 mm x 324 mm) | |
| Shipping Weight | 11.5 lb (5.2 kg) | |
| Net Weight | 9.0 lb (4.1 kg) | |
| Cooling System | Single fan creates continuous left-to-right air flow | |
| General | | |
| Inputs (Control) | 1 RJ-45 remote input for CC-1 ControlCenter zone controllers or Volume Control user interface (PC041966). Mute input control via a normally open contact closure. | |

ZA 2120-HZA Specifications

| Power Rating | | |
|--------------------------------|---|--|
| Amplifier Power | 2 x 120 W @ 70/100 V | |
| Audio Performance | | |
| Frequency Response | 55 Hz - 20 kHz (+0/-3 dB, @ 1 W reference 1 kHz) | |
| THD+N | ≤ 0.3 % (at rated power) | |
| Channel Separation (Crosstalk) | ≤ -58 dBu (below rated power, 1 kHz) | |
| Dynamic Range | 88 dB | |
| Audio Inputs | | AmpLink |
| Input Channels | 1 unbalanced, 1 balanced | 8 digital |
| Connectors | Stereo RCA, 5-pin Euroblock | RJ-45 (Input) |
| Input Range | -8 dBu to 22 dBu | |
| Input Impedance | 20 kΩ | |
| Maximum Input Level | 22 dBu | |
| Nominal Input Level | 4 dBu | |
| Audio Latency | 1 ms (analog input to loudspeaker output) | 1.5 ms (AmpLink input to loudspeaker output) |
| Audio Outputs | | AmpLink |
| Outputs | 2 | 8 digital |
| Connectors | 2-pin inverted Euroblock | RJ-45 (Thru) |
| Nominal Output Level | 2 x 120 W @ 4 Ω, 2 x 60 W @ 8 Ω | |
| Indicators and Controls | | |
| Power LED | Solid blue indicates power is on, blinking blue indicates standby mode. | |
| Input Signal Clip LED | Green indicates input signal is within -37 dBu to 11 dBu, red indicates signal is over 11 dBu. | |
| Output Signal Clip LED | Green indicates output signal is within -46 dBFS to -2 dBFS, red indicates signal is over -2 dBFS, approximately 80 W/channel, for each output 120 watts is 0 dBFS. | |
| AmpLink ERR LED | Solid yellow indicates muted audio from the mute connector. Blinking yellow indicates an error, which will also mute the audio. | |
| AmpLink LNK LED | Solid green indicates normal operation. | |
| Controls, Front Panel | Power On/Off | |
| Controls, Rear Panel | Auto Standby: On/Off switch, Output: Stereo/Mono switch, Mute, Output trims, Remote RJ-45 | |
| Electrical | | |
| Mains Voltage | 100 VAC - 240 VAC (±10 %, 50/60 Hz) | |
| AC Power Consumption | 13.0 W (Standby), 300 W (Max) | |
| Mains Connector | Standard IEC (C14) | |
| Maximum Inrush Current | 12.6 Amps (230 VAC / 50 Hz), 7.8 Amps (120 VAC / 60 Hz) | |
| Overload Protection | High temperature, output short, excessively low or high AC line voltage | |
| Physical | | |
| Dimensions | 1.7" H x 19.0" W x 12.8" D (44 mm x 483 mm x 324 mm) | |
| Shipping Weight | 11.7 lb (5.3 kg) | |
| Net Weight | 9.5 lb (4.3 kg) | |
| Cooling System | Single fan creates continuous left-to-right air flow | |
| General | | |
| Inputs (Control) | 1 RJ-45 remote input for CC-1 ControlCenter zone controllers or Volume Control user interface (PC041966). Mute input control via a normally open contact closure. | |

Troubleshooting

| Problem | What to do |
|---|---|
| <ul style="list-style-type: none"> No power | <ul style="list-style-type: none"> Turn on power. Blue LED on front-panel will be visible when power is on. Make sure the power cord is plugged in. Try a different AC outlet that is working with another piece of equipment. |
| <ul style="list-style-type: none"> Power is on, but no sound | <ul style="list-style-type: none"> Make sure the input source is turned on. Verify that there is an input signal from the source. Check the cable connections from the source to the amplifier. Ensure the desired source (A/B) is selected on the front panel. If a user interface is connected to the REMOTE connector on the rear panel, make sure the desired source (A/B) is selected on user interface (user interface overrides the front-panel source select). Make sure the MASTER LEVEL control is turned up. If a user interface is connected to the REMOTE connector on the rear panel, make sure the volume control on the user interface is turned up (user interface overrides the front-panel MASTER LEVEL control). Make sure a 1/8" (3.5 mm) TRS input cable is not connected to the AUX INPUT. The AUX INPUT has a mechanical override feature so if an input cable is connected to it the selected Input A/B source will be automatically overridden - even if the AUX INPUT audio source is not playing or connected. If a contact closure is connected to the MUTE connector on the rear panel, check the switch to ensure the mute function has not been triggered. If a source is connected to the PAGE INPUT connector on the rear panel, make sure it has not been triggered. Make sure loudspeakers are connected properly. Make sure that loudspeaker taps are set correctly. See "Loudspeaker Usage" on page 33. Check that the amplifier has adequate ventilation. Improper ventilation could cause the amplifier to go into protection mode and no audio will be heard. Ensure that the output wiring is correct. A short circuit will cause the amplifier to go into protection mode and no audio will be heard. |
| <ul style="list-style-type: none"> Power is on, but sound is low | <ul style="list-style-type: none"> Verify that the audio input source output is turned up to a nominal level. Check the cable connections from the source to the amplifier. Increase input level of source with GAIN controls on amplifier. Turn GAIN knob clockwise until you start seeing a red INPUT SIGNAL CLIP LED on front-panel. Then turn GAIN counter-clockwise until the LED turns green. Make sure OUTPUT TRIM controls on amplifier are not turned down too low. If a user interface is connected to the REMOTE connector on the rear panel, make sure the volume control on the user interface is turned up (user interface overrides the front-panel MASTER LEVEL control). Make sure that loudspeaker taps are set correctly. See "Loudspeaker Usage" on page 33. |
| <ul style="list-style-type: none"> Sound is distorted | <ul style="list-style-type: none"> Verify that the INPUT SIGNAL CLIP LED on the front-panel is not red. If it is red, reduce the source output level or reduce the input gain. If the input source signal is clean, verify that the loudspeakers are not overdriven or damaged. Check the loudspeaker tap setting. |
| <ul style="list-style-type: none"> Unnatural sound | <ul style="list-style-type: none"> Verify that the proper EQ preset is selected for the loudspeakers being used. With the IZA 2120-HZ, use the HPF setting for loudspeakers other than FreeSpace® loudspeakers and those that have their own EQ settings. Check the TREBLE and BASS controls on the front-panels. |

Digital Signal Processor

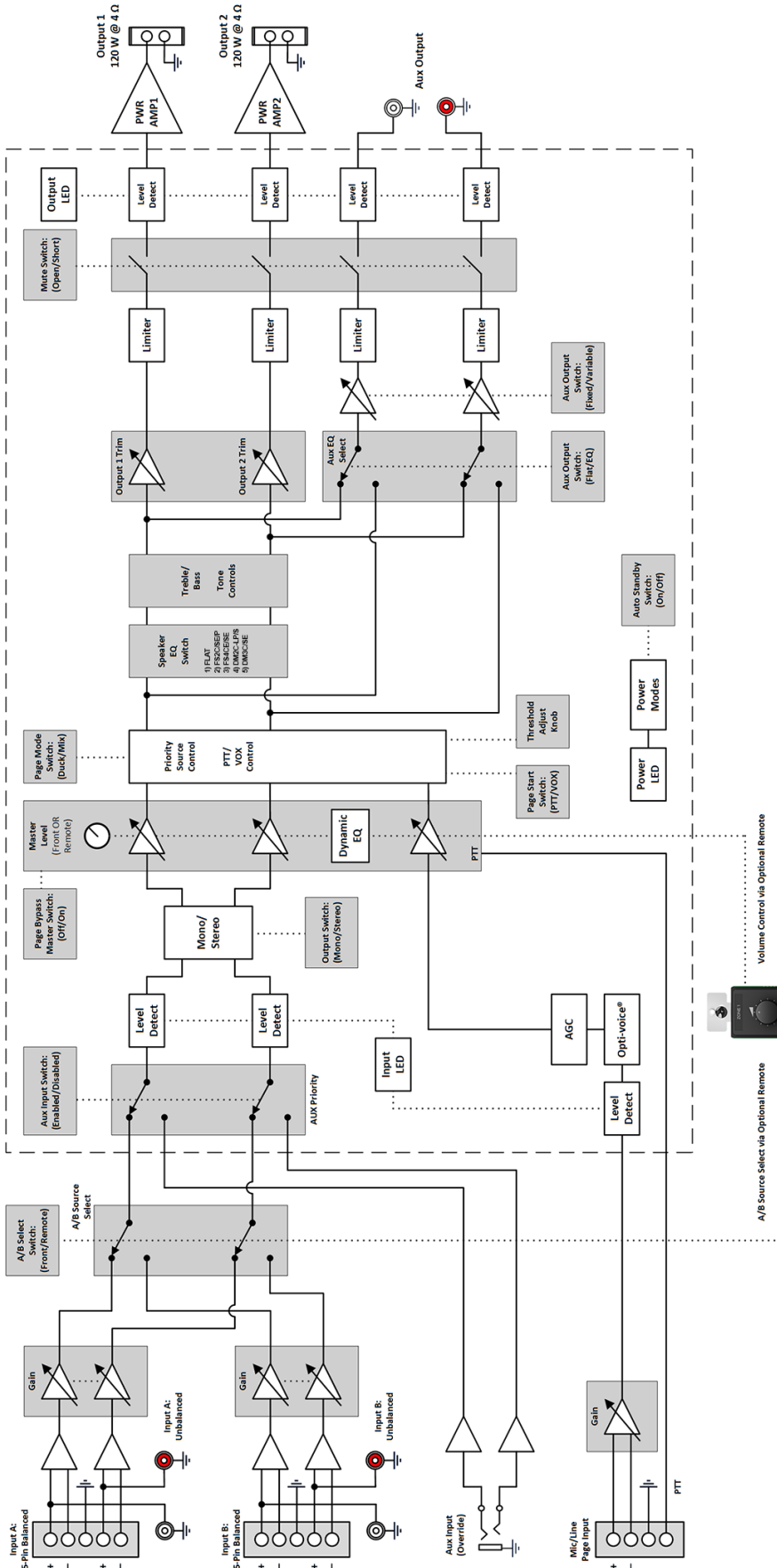

Optional EC-2 Zone Controller Remote for Control with A/B Source Selection Switch

IZA 2120-LZ Integrated Zone Amplifier

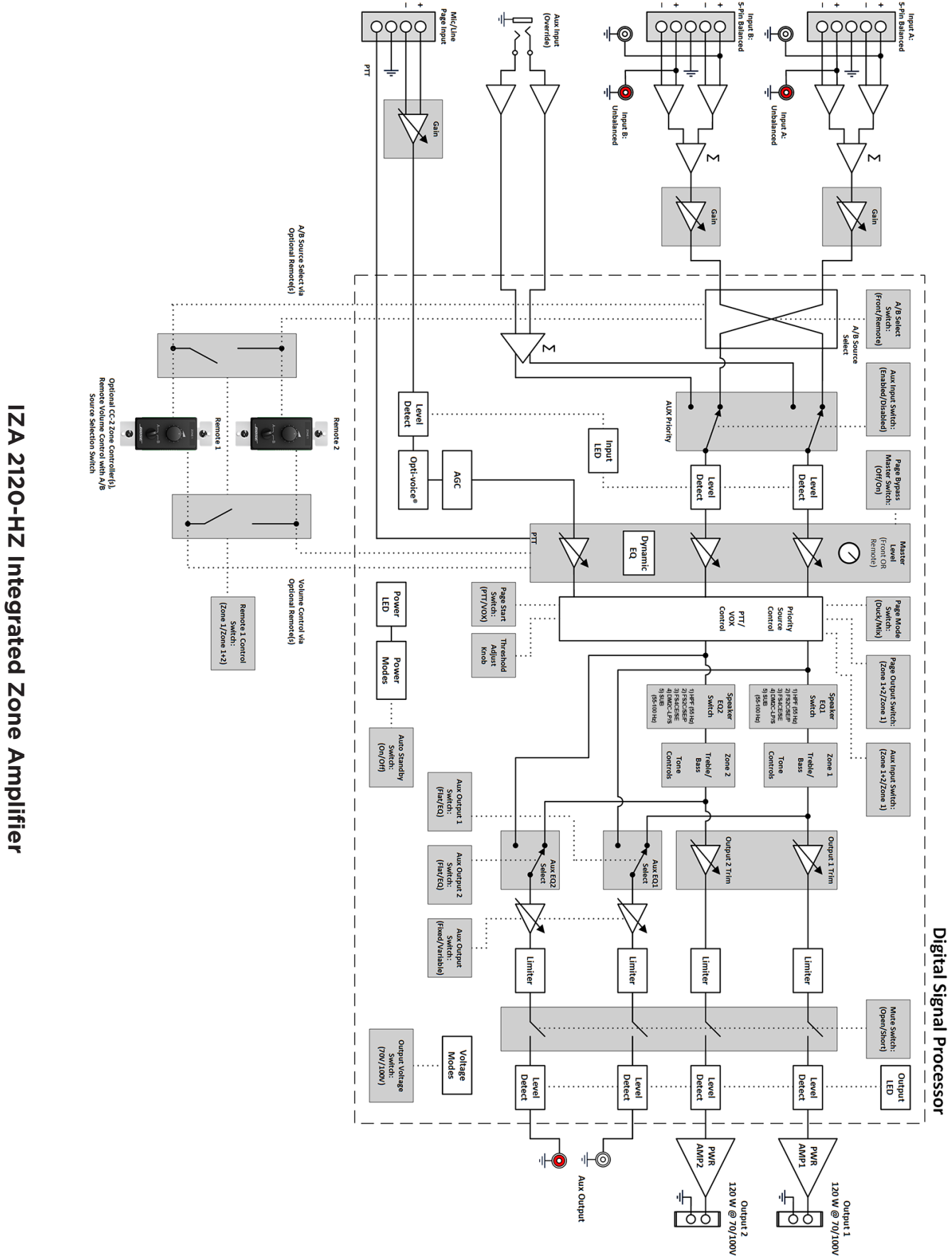

IZA 2120-HZ Integrated Zone Amplifier

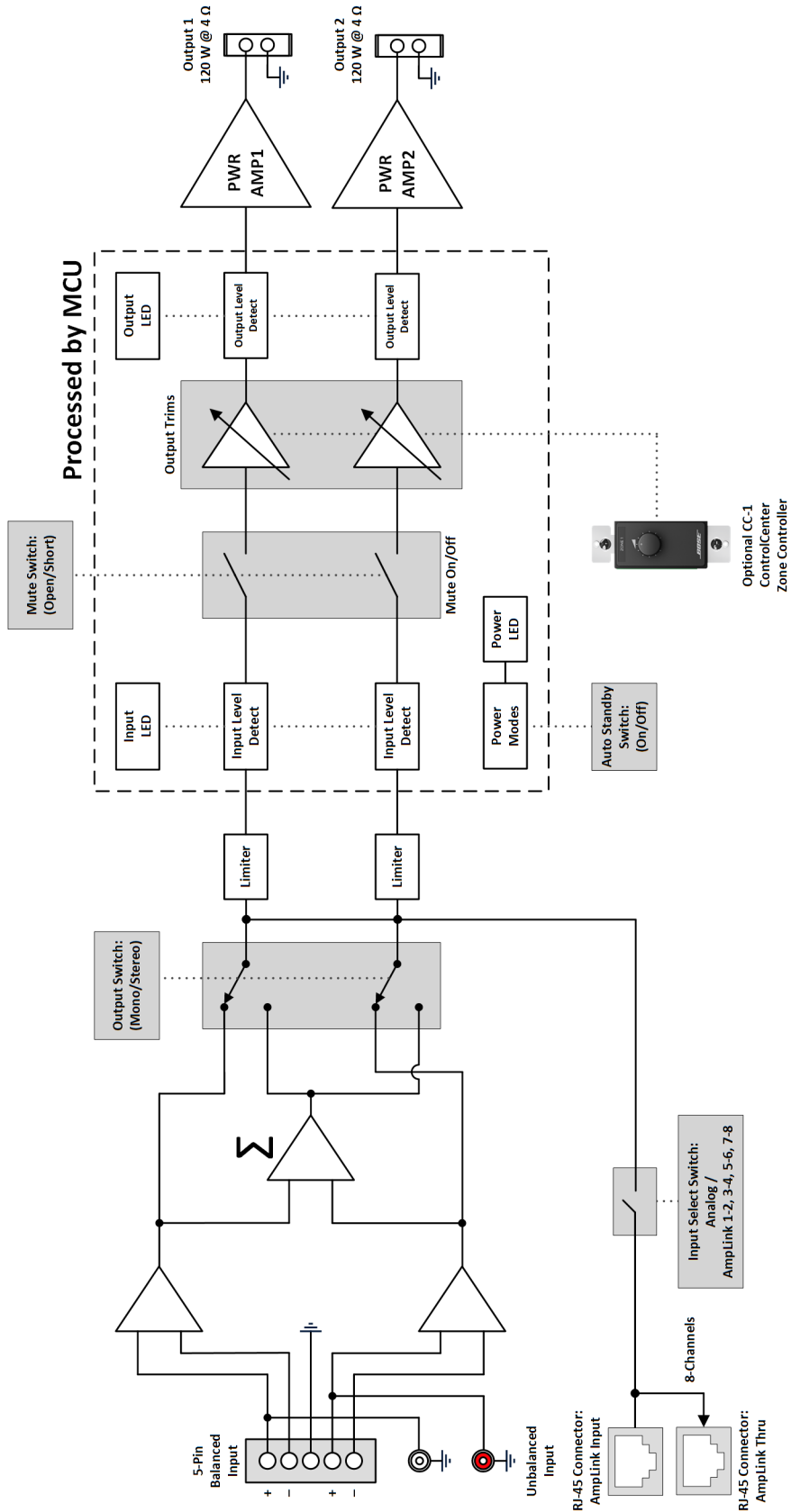

ZA 2120-LZA Zone Amplifier

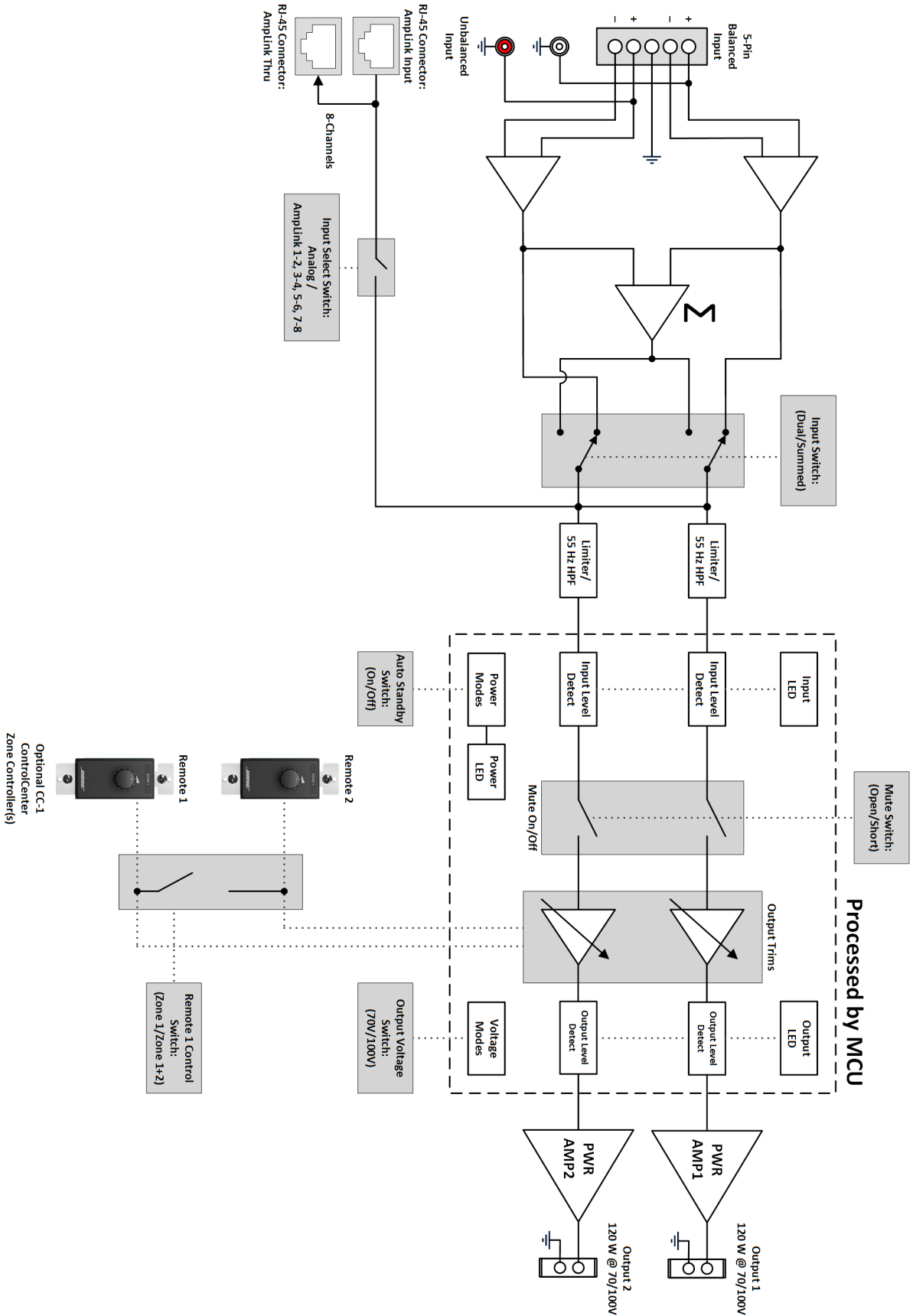

ZA 2120-HZA Zone Amplifier

Additional Information

Refer to the owner's guide (online at pro.Bose.com) for more information about your product (including accessories and replacement parts). To request a printed copy, use the phone numbers provided.

Limited Warranty

Your product is covered by a limited warranty. Visit pro.Bose.com for warranty details.

The warranty information provided with this product does not apply in Australia and New Zealand. See our website at www.bose.com/au/warranty or www.bose.com/nz/warranty for details of the Australian and New Zealand warranty.

Date of Manufacture

The eighth digit in the serial number indicates the year of manufacture; "6" is 2006 or 2016.

Importer Information

China Importer: Bose Electronics (Shanghai) Company Limited, Part C, Plant 9, No. 353 North Riyang Road, China (Shanghai) Pilot Free Trade Zone

EU Importer: Bose Products B.V., Gorslaan 60, 1441 RG Purmerend, The Netherlands

Mexico Importer: Bose de México, S. de R.L. de C.V. , Paseo de las Palmas 405-204, Lomas de Chapultepec, 11000 México, D.F. For importer & service information: +5255 (5202) 3545

Taiwan Importer: Bose Taiwan Branch, 9F-A1, No. 10, Section 3, Minsheng East Road, Taipei City 104, Taiwan. Phone Number: +886-2-2514 7676



857568-0010

©2019 Bose Corporation, All rights reserved.
Framingham, MA 01701-9168 USA
PRO.BOSE.COM
AM857568 Rev. 00
December 2019

